

CITY MULTI™ OUTDOOR UNITS

R2 SERIES

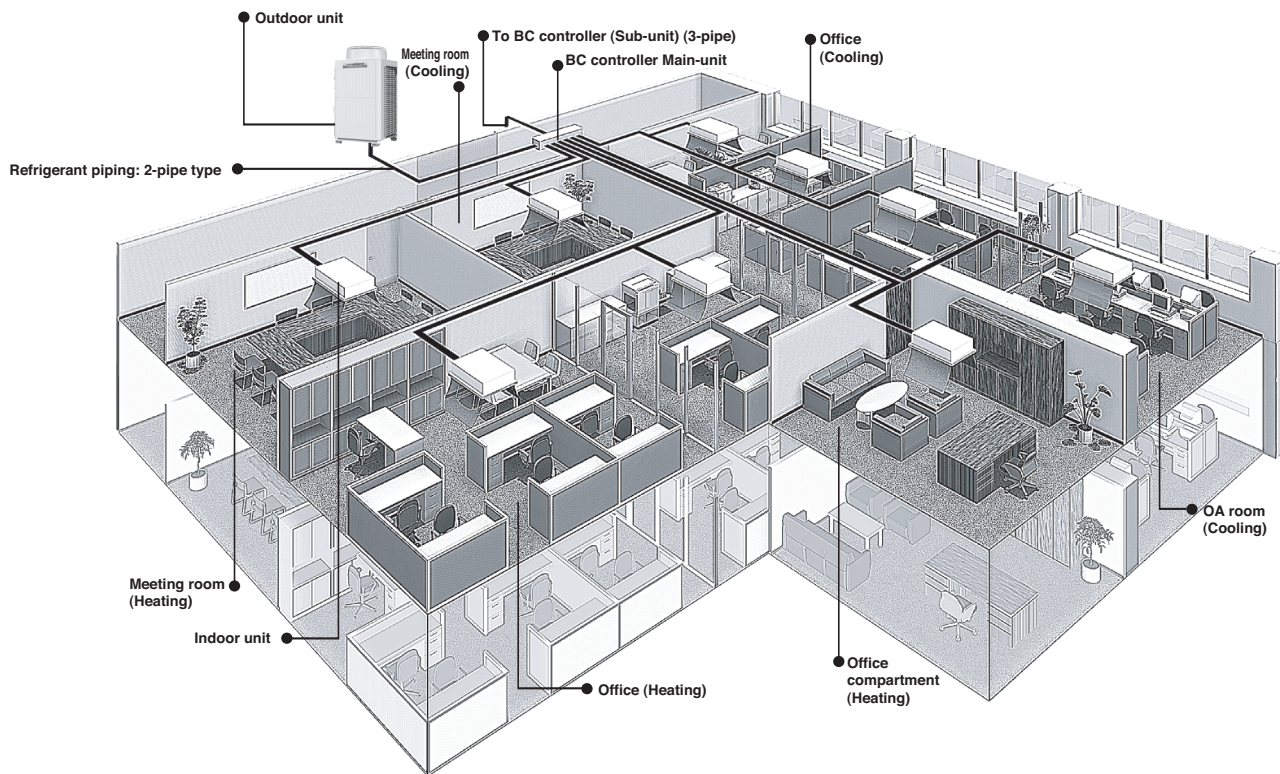

Heat pump: PURY-P-Y(S)HM-A(-BS)

	250	300	350	400	500	550	600	650	700	750	800
	10HP	12HP	14HP	16HP	20HP	22HP	24HP	26HP	28HP	30HP	32HP
R2 Heat recovery	●	●	●	●	●	●	●	●	●	●	●

Ref: PURY_YHM-A_DOC_EUDB_ALL_R1

Model		PURY-P250YHM-A(-BS)	
Power source		3-phase 4-wire 380-400-415V 50/60Hz	
Cooling capacity (Nominal)	*1 kW	28.0	
	*1 kcal / h	24,100	
	*1 Btu / h	95,500	
	*2 kcal / h	25,000	
	Power input kW	7.73	
Current input	A	13.0-12.3-11.9	
COP	kW / kW	3.62	
Temp. range of cooling *4	Indoor	W.B.	15 to 24degC(59 to 75degF)
	Outdoor	D.B.	-5 to 43degC(23 to 109degF)
Heating capacity (Nominal)	*3 kW	31.5	
	*3 kcal / h	27,100	
	*3 Btu / h	107,500	
	Power input kW	7.83	
	Current input	A	13.2-12.5-12.1
COP	kW / kW	4.02	
Temp. range of heating *4	Indoor temp.	D.B.	15 to 27degC(59 to 81degF)
	Outdoor temp.	W.B.	-20 to 15.5degC(-4 to 60degF)
Indoor unit connectable	Total capacity	50 to 150 % of outdoor unit capacity	
	Model / Quantity	P15 to P250 / 1 to 25	
Noise level (measured in anechoic room)		dB <A> 57.0	
Diameter of refrigerant pipe	High pressure	mm(in.)	19.05(3/4") Brazed
	Low pressure	mm(in.)	22.22(7/8") Brazed
External finish	Pre-coated galvanized steel sheet (+powder coating for -BS type) <MUNSELL 5Y 8/1>		
External dimension HxWxD	mm	1,710(1,650 without legs) x 920 x 760	
	in.	67-3/8"(65" without legs) x 36-1/4" x 29-15/16"	
Net weight	kg(lb)	235(519)	
Heat exchanger	Salt-resistant cross fin & copper tube		
Compressor	Type	Inverter scroll hermetic compressor	
	Maker	AC&R Works, MITSUBISHI ELECTRIC CORPORATION	
	Starting method	Inverter	
	Motor output	kW	6.7
	Case heater	kW	0.035(240 V)
	Lubricant	MEL32	
FAN	Air flow rate	m ³ / min	185
		L/s	3,083
		cfm	6,532
	External static press.	0 - 30 - 60Pa	
	Type x Quantity	Propeller fan x 1	
	Control, Driving mechanism	Inverter-control, Direct-driven by motor	
	Motor output	kW	0.92
HIC circuit (HIC: Heat Inter-Changer)	-		
Protection	High pressure protection	High pressure sensor, High pressure switch at 4.15MPa (601 psi)	
	Inverter circuit (COMP. / FAN)	Over-heat protection, Over-current protection	
	Compressor	Over-heat protection, Over-current protection	
	Fan motor	Thermal switch	
Defrosting method	Auto-defrost mode (Reversed refrigerant circle)		
Refrigerant	Type x original charge	R410A x 10.5kg (24lb)	
	Control	Indoor LEV and BC controller	
Drawing	External	WKB94G529	
	Wiring	WKE94C141	
Standard attachment	Document	Installation Manual	
	Accessory	Details refer to External Drw	
Optional parts	joint: CMY-Y102S-G2, CMY-Y102L-G2, CMY-R160-J BC controller: CMB-P104, 105, 106, 108, 1010, 1013, 1016V-G Main BC controller: CMB-P108, 1010, 1013, 1016V-GA Sub BC controller: CMB-P104, 108V-GB, CMB-P1016V-HB		
Remark	Details on foundation work, duct work, insulation work, electrical wiring, power source switch, and other items shall be referred to the Installation Manual.		

Note :	*1 Nominal cooling conditions	*2 Nominal cooling conditions	*3 Nominal heating conditions	Unit converter
Indoor :	27degCDB/19degCWB (81degFDB/66degFWB)	27degCDB/19.5degCWB (81degFDB/67degFWB)	20degCDB (68degFDB)	kcal =kW x 860
Outdoor :	35degCDB (95degFDB)	35degCDB (95degFDB)	7degCDB/6degCWB (45degFDB/43degFWB)	Btu/h =kW x 3,412
Pipe length :	7.5m(24-9/16"ft.)	5m(16-3/8"ft.)	7.5m(24-9/16"ft.)	cfm =m ³ /min x 35.31
Level difference :	0m(0ft.)	0m(0ft.)	0m(0ft.)	lb =kg / 0.4536
*4 -5degC(23degF)DB/-6degC(21degF)WB to 21degC(70degF)DB/15.5degC(60degF)WB with cooling/heating mixed operation.				
* Nominal condition *1, *3 are subject to JIS B8615-1				
* Due to continuing improvement, above specifications may be subject to change without notice.				
				*Above specification data is subject to rounding variation.

Ref.:PURY_YHM-A_SPC_EUDB_P200-P250_56

1. SPECIFICATIONS

DATA G4

Model		PURY-P300YHM-A(-BS)		PURY-P350YHM-A(-BS)	
Power source		3-phase 4-wire 380-400-415V 50/60Hz			
Cooling capacity (Nominal)	*1	kW	33.5	40.0	
	*1	kcal / h	28,800	34,400	
	*1	Btu / h	114,300	136,500	
	*2	kcal / h	30,000	35,000	
	Power input	kW	9.25	12.47	
	Current input	A	15.6-14.8-14.2	21.0-19.9-19.2	
COP	kW / kW	3.62	3.20		
Temp. range of cooling *4	Indoor	W.B.	15 to 24degC(59 to 75degF)		
	Outdoor	D.B.	-5 to 43degC(23 to 109degF)		
Heating capacity (Nominal)	*3	kW	37.5	45.0	
	*3	kcal / h	32,300	38,700	
	*3	Btu / h	128,000	153,500	
	Power input	kW	9.58	12.47	
	Current input	A	16.1-15.3-14.8	21.0-19.9-19.2	
	COP	kW / kW	3.91	3.60	
Temp. range of heating *4	Indoor temp.	D.B.	15 to 27degC(59 to 81degF)		
	Outdoor temp.	W.B.	-20 to 15.5degC(-4 to 60degF)		
Indoor unit connectable	Total capacity	50 to 150 % of outdoor unit capacity			
	Model / Quantity	P15 to P250 / 1 to 30		P15 to P250 / 1 to 35	
Noise level (measured in anechoic room)	dB <A>	59.0		60.0	
Diameter of refrigerant pipe	High pressure	mm(in.)	19.05(3/4") Brazed		
	Low pressure	mm(in.)	22.22(7/8") Brazed	28.58(1-1/8") Brazed	
External finish		Pre-coated galvanized steel sheet (+powder coating for -BS type) <MUNSELL 5Y 8/1>			
External dimension HxWxD	mm	1,710(1,650 without legs) x 920 x 760		1,710(1,650 without legs) x 1,220 x 760	
	in.	67-3/8"(65" without legs) x 36-1/4" x 29-15/16"		67-3/8"(65" without legs) x 48-1/16" x 29-15/16"	
Net weight	kg(lb)	240(530)		265(585)	
Heat exchanger		Salt-resistant cross fin & copper tube			
Compressor	Type	Inverter scroll hermetic compressor			
	Maker	AC&R Works, MITSUBISHI ELECTRIC CORPORATION			
	Starting method	Inverter			
	Motor output	kW	8.2	10.3	
	Case heater	kW	0.045(240 V)		
	Lubricant	MEL32			
FAN	Air flow rate	m ³ / min	185	225	
		L/s	3,083	3,750	
		cfm	6,532	7,945	
	External static press.	0-30-60Pa			
	Type x Quantity	Propeller fan x 1			
	Control, Driving mechanism	Inverter-control, Direct-driven by motor			
Motor output	kW	0.92			
HIC circuit (HIC: Heat Inter-Changer)		-			
Protection	High pressure protection	High pressure sensor, High pressure switch at 4.15MPa (601 psi)			
	Inverter circuit (COMP. / FAN)	Over-heat protection, Over-current protection			
	Compressor	Over-heat protection, Over-current protection			
	Fan motor	Thermal switch			
Defrosting method		Auto-defrost mode (Reversed refrigerant circle)			
Refrigerant	Type x original charge	R410A x 10.5kg (24lb)		R410A x 13.0kg (29lb)	
	Control	Indoor LEV and BC controller			
Drawing	External	WKB94G529		WKB94G530	
	Wiring	WKE94C141			
Standard attachment	Document	Installation Manual			
	Accessory	Details refer to External Drw			
Optional parts		joint: CMY-Y102S-G2, CMY-Y102L-G2, CMY-Y202-G2, CMY-R160-J BC controller: CMB-P104, 105, 106, 108, 1010, 1013, 1016V-G Main BC controller: CMB-P108, 1010, 1013, 1016V-GA Sub BC controller: CMB-P104, 108V-GB, CMB-P1016V-HB			
Remark		Details on foundation work, duct work, insulation work, electrical wiring, power source switch, and other items shall be referred to the Installation Manual.			

Note :	*1 Nominal cooling conditions	*2 Nominal cooling conditions	*3 Nominal heating conditions	Unit converter
Indoor :	27degCDB/19degCWB (81degFDB/66degFWB)	27degCDB/19.5degCWB (81degFDB/67degFWB)	20degCDB (68degFDB)	kcal =kW x 860
Outdoor :	35degCDB (95degFDB)	35degCDB (95degFDB)	7degCDB/6degCWB (45degFDB/43degFWB)	Btu/h =kW x 3,412
Pipe length :	7.5m(24-9/16"ft.)	5m(16-3/8"ft.)	7.5m(24-9/16"ft.)	cfm =m ³ /min x 35.31
Level difference :	0m(0ft.)	0m(0ft.)	0m(0ft.)	lb =kg / 0.4536
*4 -5degC(23degF)DB/-6degC(21degF)WB to 21degC(70degF)DB/15.5degC(60degF)WB with cooling/heating mixed operation.				
* Nominal condition *1, *3 are subject to JIS B8615-1				
* Due to continuing improvement, above specifications may be subject to change without notice.				
				*Above specification data is subject to rounding variation.

Ref.:PURY_YHM-A_SPC_EUDB_P300-P350_56

Model			PURY-P400YHM-A(-BS)			
Power source			3-phase 4-wire 380-400-415V 50/60Hz			
Cooling capacity (Nominal)	*1	kW	45.0			
	*1	kcal / h	38,700			
	*1	Btu / h	153,500			
	*2	kcal / h	40,000			
		Power input	kW	13.74		
		Current input	A	23.1-22.0-21.2		
		COP	kW / kW	3.27		
Temp. range of cooling *4	Indoor	W.B.	15 to 24degC(59 to 75degF)			
	Outdoor	D.B.	-5 to 43degC(23 to 109degF)			
Heating capacity (Nominal)	*3	kW	50.0			
	*3	kcal / h	43,000			
	*3	Btu / h	170,600			
		Power input	kW	13.71		
			Current input	A	23.1-21.9-21.1	
		COP	kW / kW	3.64		
Temp. range of heating *4	Indoor temp.	D.B.	15 to 27degC(59 to 81degF)			
	Outdoor temp.	W.B.	-20 to 15.5degC(-4 to 60degF)			
Indoor unit connectable	Total capacity		50 to 150 % of outdoor unit capacity			
	Model / Quantity		P15 to P250 / 1 to 40			
Noise level (measured in anechoic room)		dB <A>		61.0		
Diameter of refrigerant pipe	High pressure	mm(in.)	22.22(7/8") Brazed			
	Low pressure	mm(in.)	28.58(1-1/8") Brazed			
External finish			Pre-coated galvanized steel sheet (+powder coating for -BS type) <MUNSELL 5Y 8/1>			
External dimension HxWxD	mm		1,710(1,650 without legs) x 1,220 x 760			
	in.		67-3/8"(65" without legs) x 48-1/16" x 29-15/16"			
Net weight		kg(lb)		265(585)		
Heat exchanger			Salt-resistant cross fin & copper tube			
Compressor	Type		Inverter scroll hermetic compressor			
	Maker		AC&R Works, MITSUBISHI ELECTRIC CORPORATION			
	Starting method		Inverter			
	Motor output	kW	10.5			
	Case heater	kW	0.045(240 V)			
	Lubricant		MEL32			
FAN	Air flow rate	m ³ / min	225			
		L/s	3,750			
		cfm	7,945			
	External static press.		0 - 30 - 60Pa			
	Type x Quantity		Propeller fan x 1			
	Control, Driving mechanism		Inverter-control, Direct-driven by motor			
Motor output	kW	0.92				
HIC circuit (HIC: Heat Inter-Changer)			-			
Protection	High pressure protection		High pressure sensor, High pressure switch at 4.15MPa (601 psi)			
	Inverter circuit (COMP. / FAN)		Over-heat protection, Over-current protection			
	Compressor		Over-heat protection, Over-current protection			
	Fan motor		Thermal switch			
Defrosting method			Auto-defrost mode (Reversed refrigerant circle)			
Refrigerant	Type x original charge		R410A x 13.0kg (29lb)			
	Control		Indoor LEV and BC controller			
Drawing	External		WKB94G530			
	Wiring		WKE94C141			
Standard attachment	Document		Installation Manual			
	Accessory		Details refer to External Drw			
Optional parts			joint: CMY-Y102S-G2, CMY-Y102L-G2, CMY-Y202-G2, CMY-R160-J Main BC controller: CMB-P108, 1010, 1013, 1016V-GA Sub BC controller: CMB-P104, 108V-GB, CMB-P1016V-HB			
Remark			Details on foundation work, duct work, insulation work, electrical wiring, power source switch, and other items shall be referred to the Installation Manual.			

Note :	*1 Nominal cooling conditions	*2 Nominal cooling conditions	*3 Nominal heating conditions	Unit converter
Indoor :	27degCDB/19degCWB (81degFDB/66degFWB)	27degCDB/19.5degCWB (81degFDB/67degFWB)	20degCDB (68degFDB)	kcal =kW x 860
Outdoor :	35degCDB (95degFDB)	35degCDB (95degFDB)	7degCDB/6degCWB (45degFDB/43degFWB)	Btu/h =kW x 3,412
Pipe length :	7.5m(24-9/16"ft.)	5m(16-3/8"ft.)	7.5m(24-9/16"ft.)	cfm =m ³ /min x 35.31
Level difference :	0m(0ft.)	0m(0ft.)	0m(0ft.)	lb =kg / 0.4536
*4 -5degC(23degF)DB/-6degC(21degF)WB to 21degC(70degF)DB/15.5degC(60degF)WB with cooling/heating mixed operation.				
* Nominal condition *1, *3 are subject to JIS B8615-1				
* Due to continuing improvement, above specifications may be subject to change without notice.				
				*Above specification data is subject to rounding variation.

Ref.:PURY_YHM-A_SPC_EUDB_P400_56

1. SPECIFICATIONS

DATA G4

Model			PURY-P500YSHM-A(-BS)
Power source	3-phase 4-wire 380-400-415V 50/60Hz		
Cooling capacity (Nominal)	*1	kW	56.0
	*1	kcal / h	48,200
	*1	Btu / h	191,100
	*2	kcal / h	50,000
	Power input	kW	16.75
	Current input	A	28.2-26.8-25.8
	COP	kW / kW	3.34
Temp. range of cooling *4	Indoor	W.B.	15 to 24degC(59 to 75degF)
	Outdoor	D.B.	-5 to 43degC(23 to 109degF)
Heating capacity (Nominal)	*3	kW	63.0
	*3	kcal / h	54,200
	*3	Btu / h	215,000
	Power input	kW	16.79
	Current input	A	28.3-26.9-25.9
	COP	kW / kW	3.75
Temp. range of heating *4	Indoor temp.	D.B.	15 to 27degC(59 to 81degF)
	Outdoor temp.	W.B.	-20 to 15.5degC(-4 to 60degF)
Indoor unit connectable	Total capacity	50 to 150 % of outdoor unit capacity	
	Model / Quantity	P15 to P250 / 1 to 50 (Connectable branch pipe number is max. 48.)	
Noise level (measured in anechoic room)	dB <A>	60.0	
Diameter of refrigerant pipe	High pressure	mm(in.)	22.22(7/8") Brazed
	Low pressure	mm(in.)	28.58(1-1/8") Brazed

Set Model			PURY-P250YHM-A(-BS)	PURY-P250YHM-A(-BS)
External finish			Pre-coated galvanized steel sheet (+powder coating for -BS type) <MUNSELL 5Y 8/1>	Pre-coated galvanized steel sheet (+powder coating for -BS type) <MUNSELL 5Y 8/1>
External dimension HxWxD	mm		1,710(1,650 without legs) x 920 x 760	1,710(1,650 without legs) x 920 x 760
	in.		67-3/8"(65" without legs) x 36-1/4" x 29-15/16"	67-3/8"(65" without legs) x 36-1/4" x 29-15/16"
Net weight	kg(lb)		235(519)	235(519)
Heat exchanger			Salt-resistant cross fin & copper tube	
Compressor	Type		Inverter scroll hermetic compressor	
	Maker		AC&R Works, MITSUBISHI ELECTRIC CORPORATION	
	Starting method		Inverter	
	Motor output	kW	6.7	6.7
	Case heater	kW	0.035(240 V)	0.035(240 V)
	Lubricant		MEL32	
FAN	Air flow rate	m ³ / min	185	185
		L/s	3,083	3,083
		cfm	6,532	6,532
	External static press.		0 - 30 - 60Pa	
	Type x Quantity		Propeller fan x 1	
	Control, Driving mechanism		Inverter-control, Direct-driven by motor	
Motor output	kW	0.92	0.92	
HIC circuit (HIC: Heat Inter-Changer)			-	
Protection	High pressure protection		High pressure sensor, High pressure switch at 4.15MPa (601 psi)	
	Inverter circuit (COMP. / FAN)		Over-heat protection, Over-current protection	
	Compressor		Over-heat protection, Over-current protection	
	Fan motor		Thermal switch	
Defrosting method			Auto-defrost mode (Reversed refrigerant circle)	
Refrigerant	Type x original charge		R410A x 10.5kg (24lb)	R410A x 10.5kg (24lb)
	Control		Indoor LEV and BC controller	
Pipe between unit and distributor	High pressure	mm(in.)	19.05(3/4")Brazed	19.05(3/4")Brazed
	Low pressure	mm(in.)	22.22(7/8")Brazed	22.22(7/8")Brazed
Drawing	External		WKB94G549	
	Wiring		WKE94C141	
Standard attachment	Document		Installation Manual	
	Accessory		Details refer to External Drw	
Optional parts			Outdoor Twinning kit: CMY-R100VBK joint: CMY-Y102S-G2, CMY-Y102L-G2, CMY-Y202-G2, CMY-R160-J Main BC controller: CMB-P108, 1010, 1013, 1016V-GA Sub BC controller: CMB-P104, 108V-GB, CMB-P1016V-HB	
Remark			Details on foundation work, duct work, insulation work, electrical wiring, power source switch, and other items shall be referred to the Installation Manual. Systems with considerably long pipe runs, in heating mode, may be subject to slightly louder than normal noise from the outdoor unit/s. The outdoor twinning kit(low pressure) should be connected to the low pressure side of the outdoor unit. If the connected units are of different capacities, the outdoor twinning kit(low pressure) should be installed in the unit with the largest capacity.	

Note :	*1 Nominal cooling conditions	*2 Nominal cooling conditions	*3 Nominal heating conditions	Unit converter
Indoor :	27degCDB/19degCWB (81degFDB/66degFWB)	27degCDB/19.5degCWB (81degFDB/67degFWB)	20degCDB (68degFDB)	kcal =kW x 860
Outdoor :	35degCDB (95degFDB)	35degCDB (95degFDB)	7degCDB/6degCWB (45degFDB/43degFWB)	Btu/h =kW x 3,412
Pipe length :	7.5m(24-9/16"ft.)	5m(16-3/8"ft.)	7.5m(24-9/16"ft.)	cfm =m ³ /min x 35.31
Level difference :	0m(0ft.)	0m(0ft.)	0m(0ft.)	lb =kg / 0.4536
*4 -5degC(23degF)DB/-6degC(21degF)WB to 21degC(70degF)DB/15.5degC(60degF)WB with cooling/heating mixed operation.				
* Nominal condition *1, *3 are subject to JIS B8615-1				
* Due to continuing improvement, above specifications may be subject to change withoutnotice.				
				*Above specification data is subject to rounding variation.

Ref.:PURY_YHM-A_SPC_EUDB_P500_56

Model			PURY-P550YSHM-A(-BS)		
Power source	3-phase 4-wire 380-400-415V 50/60Hz				
Cooling capacity (Nominal)	*1	kW	63.0		
	*1	kcal / h	54,200		
	*1	Btu / h	215,000		
	*2	kcal / h	55,000		
		Power input	kW	18.68	
	Current input	A	31.5-29.9-28.8		
	COP	kW / kW	3.37		
Temp. range of cooling *4	Indoor	W.B.	15 to 24degC(59 to 75degF)		
	Outdoor	D.B.	-5 to 43degC(23 to 109degF)		
Heating capacity (Nominal)	*3	kW	69.0		
	*3	kcal / h	59,300		
	*3	Btu / h	235,400		
		Power input	kW	18.81	
		Current input	A	31.7-30.1-29.0	
	COP	kW / kW	3.66		
Temp. range of heating *4	Indoor temp.	D.B.	15 to 27degC(59 to 81degF)		
	Outdoor temp.	W.B.	-20 to 15.5degC(-4 to 60degF)		
Indoor unit connectable	Total capacity	50 to 150 % of outdoor unit capacity			
	Model / Quantity	P15 to P250 / 2 to 50 (Connectable branch pipe number is max. 48.)			
Noise level (measured in anechoic room)		dB <A>	61.0		
Diameter of refrigerant pipe	High pressure	mm(in.)	28.58(1-1/8") Brazed		
	Low pressure	mm(in.)	28.58(1-1/8") Brazed		

Set Model			PURY-P250YHM-A(-BS)		PURY-P300YHM-A(-BS)	
External finish			Pre-coated galvanized steel sheet (+powder coating for -BS type) <MUNSELL 5Y 8/1>		Pre-coated galvanized steel sheet (+powder coating for -BS type) <MUNSELL 5Y 8/1>	
External dimension HxWxD	mm	1,710(1,650 without legs) x 920 x 760		1,710(1,650 without legs) x 920 x 760		
	in.	67-3/8"(65" without legs) x 36-1/4" x 29-15/16"		67-3/8"(65" without legs) x 36-1/4" x 29-15/16"		
Net weight	kg(lb)	235(519)		240(530)		
Heat exchanger			Salt-resistant cross fin & copper tube		Salt-resistant cross fin & copper tube	
Compressor	Type	Inverter scroll hermetic compressor		Inverter scroll hermetic compressor		
	Maker	AC&R Works, MITSUBISHI ELECTRIC CORPORATION		AC&R Works, MITSUBISHI ELECTRIC CORPORATION		
	Starting method	Inverter		Inverter		
	Motor output	kW	6.7		8.2	
	Case heater	kW	0.035(240 V)		0.045(240 V)	
	Lubricant	MEL32		MEL32		
FAN	Air flow rate	m ³ / min	185		185	
		L/s	3,083		3,083	
		cfm	6,532		6,532	
	External static press.	0 - 30 - 60Pa		0 - 30 - 60Pa		
	Type x Quantity	Propeller fan x 1		Propeller fan x 1		
	Control, Driving mechanism	Inverter-control, Direct-driven by motor		Inverter-control, Direct-driven by motor		
	Motor output	kW	0.92		0.92	
HIC circuit (HIC: Heat Inter-Changer)			-		-	
Protection	High pressure protection	High pressure sensor, High pressure switch at 4.15MPa (601 psi)		High pressure sensor, High pressure switch at 4.15MPa (601 psi)		
	Inverter circuit (COMP. / FAN)	Over-heat protection, Over-current protection		Over-heat protection, Over-current protection		
	Compressor	Over-heat protection, Over-current protection		Over-heat protection, Over-current protection		
	Fan motor	Thermal switch		Thermal switch		
Defrosting method			Auto-defrost mode (Reversed refrigerant circle)			
Refrigerant	Type x original charge	R410A x 10.5kg (24lb)		R410A x 10.5kg (24lb)		
	Control	Indoor LEV and BC controller				
Pipe between unit and distributor	High pressure	mm(in.)	19.05(3/4")Brazed		19.05(3/4")Brazed	
	Low pressure	mm(in.)	22.22(7/8")Brazed		22.22(7/8")Brazed	
Drawing	External	WKB94G549				
	Wiring	WKE94C141				
Standard attachment	Document	Installation Manual				
	Accessory	Details refer to External Drw				
Optional parts	Outdoor Twinning kit: CMY-R100VBK joint: CMY-Y102S-G2, CMY-Y102L-G2, CMY-Y202-G2, CMY-R160-J Main BC controller: CMB-P108, 1010, 1013, 1016V-GA Sub BC controller: CMB-P104, 108V-GB, CMB-P1016V-HB					
Remark	Details on foundation work, duct work, insulation work, electrical wiring, power source switch, and other items shall be referred to the Installation Manual. Systems with considerably long pipe runs, in heating mode, may be subject to slightly louder than normal noise from the outdoor unit/s. The outdoor twinning kit(low pressure) should be connected to the low pressure side of the outdoor unit. If the connected units are of different capacities, the outdoor twinning kit(low pressure) should be installed in the unit with the largest capacity.					

Note :	*1 Nominal cooling conditions	*2 Nominal cooling conditions	*3 Nominal heating conditions	Unit converter
Indoor :	27degCDB/19degCWB (81degFDB/66degFWB)	27degCDB/19.5degCWB (81degFDB/67degFWB)	20degCDB (68degFDB)	kcal =kW x 860
Outdoor :	35degCDB (95degFDB)	35degCDB (95degFDB)	7degCDB/6degCWB (45degFDB/43degFWB)	Btu/h =kW x 3,412
Pipe length :	7.5m(24-9/16"ft.)	5m(16-3/8"ft.)	7.5m(24-9/16"ft.)	cfm =m ³ /min x 35.31
Level difference :	0m(0ft.)	0m(0ft.)	0m(0ft.)	lb =kg / 0.4536
*4 -5degC(23degF)DB/-6degC(21degF)WB to 21degC(70degF)DB/15.5degC(60degF)WB with cooling/heating mixed operation.				
* Nominal condition *1, *3 are subject to JIS B8615-1				
* Due to continuing improvement, above specifications may be subject to change without notice.				
				*Above specification data is subject to rounding variation.

Ref.:PURY_YHM-A_SPC_EUDB_P550_56

1. SPECIFICATIONS

Model		PURY-P600YSHM-A(-BS)	
Power source		3-phase 4-wire 380-400-415V 50/60Hz	
Cooling capacity (Nominal)	*1	kW	69.0
	*1	kcal / h	59,300
	*1	Btu / h	235,400
	*2	kcal / h	60,000
	Power input	kW	19.64
	Current input	A	33.1-31.4-30.3
	COP	kW / kW	3.51
Temp. range of cooling *4	Indoor	W.B.	15 to 24degC(59 to 75degF)
	Outdoor	D.B.	-5 to 43degC(23 to 109degF)
Heating capacity (Nominal)	*3	kW	76.5
	*3	kcal / h	65,800
	*3	Btu / h	261,000
	Power input	kW	20.83
	Current input	A	35.1-33.4-32.1
	COP	kW / kW	3.67
Temp. range of heating *4	Indoor temp.	D.B.	15 to 27degC(59 to 81degF)
	Outdoor temp.	W.B.	-20 to 15.5degC(-4 to 60degF)
Indoor unit connectable	Total capacity	50 to 150 % of outdoor unit capacity	
	Model / Quantity	P15 to P250 / 2 to 50 (Connectable branch pipe number is max. 48.)	
Noise level (measured in anechoic room)	dB <A>	62.0	
Diameter of refrigerant pipe	High pressure	mm(in.)	28.58(1-1/8") Brazed
	Low pressure	mm(in.)	28.58(1-1/8") Brazed

Set Model

Model		PURY-P300YHM-A(-BS)		PURY-P300YHM-A(-BS)		
External finish		Pre-coated galvanized steel sheet (+powder coating for -BS type) <MUNSELL 5Y 8/1>		Pre-coated galvanized steel sheet (+powder coating for -BS type) <MUNSELL 5Y 8/1>		
External dimension HxWxD	mm	1,710(1,650 without legs) x 920 x 760		1,710(1,650 without legs) x 920 x 760		
	in.	67-3/8"(65" without legs) x 36-1/4" x 29-15/16"		67-3/8"(65" without legs) x 36-1/4" x 29-15/16"		
Net weight	kg(lb)	240(530)		240(530)		
Heat exchanger		Salt-resistant cross fin & copper tube		Salt-resistant cross fin & copper tube		
Compressor	Type	Inverter scroll hermetic compressor		Inverter scroll hermetic compressor		
	Maker	AC&R Works, MITSUBISHI ELECTRIC CORPORATION		AC&R Works, MITSUBISHI ELECTRIC CORPORATION		
	Starting method	Inverter		Inverter		
	Motor output	kW	8.2		8.2	
	Case heater	kW	0.045(240 V)		0.045(240 V)	
	Lubricant		MEL32		MEL32	
FAN	Air flow rate	m ³ / min	185		185	
		L/s	3,083		3,083	
		cfm	6,532		6,532	
	External static press.		0 - 30 - 60Pa		0 - 30 - 60Pa	
	Type x Quantity		Propeller fan x 1		Propeller fan x 1	
	Control, Driving mechanism		Inverter-control, Direct-driven by motor		Inverter-control, Direct-driven by motor	
Motor output	kW	0.92		0.92		
HIC circuit (HIC: Heat Inter-Changer)		-		-		
Protection	High pressure protection	High pressure sensor, High pressure switch at 4.15MPa (601 psi)		High pressure sensor, High pressure switch at 4.15MPa (601 psi)		
	Inverter circuit (COMP. / FAN)	Over-heat protection, Over-current protection		Over-heat protection, Over-current protection		
	Compressor	Over-heat protection, Over-current protection		Over-heat protection, Over-current protection		
	Fan motor	Thermal switch		Thermal switch		
Defrosting method		Auto-defrost mode (Reversed refrigerant circle)				
Refrigerant	Type x original charge	R410A x 10.5kg (24lb)		R410A x 10.5kg (24lb)		
	Control	Indoor LEV and BC controller				
Pipe between unit and distributor	High pressure	mm(in.)	19.05(3/4")Brazed		19.05(3/4")Brazed	
	Low pressure	mm(in.)	22.22(7/8")Brazed		22.22(7/8")Brazed	
Drawing	External	WKB94G549				
	Wiring	WKE94C141				
Standard attachment	Document	Installation Manual				
	Accessory	Details refer to External Drw				
Optional parts		Outdoor Twinning kit: CMY-R100VBK joint: CMY-Y102S-G2, CMY-Y102L-G2, CMY-Y202-G2, CMY-R160-J Main BC controller: CMB-P108, 1010, 1013, 1016V-GA Sub BC controller: CMB-P104, 108V-GB, CMB-P1016V-HB				
Remark		Details on foundation work, duct work, insulation work, electrical wiring, power source switch, and other items shall be referred to the Installation Manual. Systems with considerably long pipe runs, in heating mode, may be subject to slightly louder than normal noise from the outdoor unit/s. The outdoor twinning kit(low pressure) should be connected to the low pressure side of the outdoor unit. If the connected units are of different capacities, the outdoor twinning kit(low pressure) should be installed in the unit with the largest capacity.				

Note :	*1 Nominal cooling conditions	*2 Nominal cooling conditions	*3 Nominal heating conditions	Unit converter
Indoor :	27degCDB/19degCWB (81degFDB/66degFWB)	27degCDB/19.5degCWB (81degFDB/67degFWB)	20degCDB (68degFDB)	kcal =kW x 860
Outdoor :	35degCDB (95degFDB)	35degCDB (95degFDB)	7degCDB/6degCWB (45degFDB/43degFWB)	Btu/h =kW x 3,412
Pipe length :	7.5m(24-9/16"ft.)	5m(16-3/8"ft.)	7.5m(24-9/16"ft.)	cfm =m ³ /min x 35.31
Level difference :	0m(0ft.)	0m(0ft.)	0m(0ft.)	lb =kg / 0.4536
*4 -5degC(23degF)DB/-6degC(21degF)WB to 21degC(70degF)DB/15.5degC(60degF)WB with cooling/heating mixed operation.				
* Nominal condition *1, *3 are subject to JIS B8615-1				
* Due to continuing improvement, above specifications may be subject to change withoutnotice.				
				*Above specification data is subject to rounding variation.

1. SPECIFICATIONS

Model			PURY-P650YSHM-A(-BS)	
Power source			3-phase 4-wire 380-400-415V 50/60Hz	
Cooling capacity (Nominal)	*1	kW	73.0	
	*1	kcal / h	62,800	
	*1	Btu / h	249,100	
	*2	kcal / h	65,000	
		Power input	kW	22.80
	Current input	A	38.4-36.5-35.2	
	COP	kW / kW	3.20	
Temp. range of cooling *4	Indoor	W.B.	15 to 24degC(59 to 75degF)	
	Outdoor	D.B.	-5 to 43degC(23 to 109degF)	
Heating capacity (Nominal)	*3	kW	81.5	
	*3	kcal / h	70,100	
	*3	Btu / h	278,100	
		Power input	kW	22.55
		Current input	A	38.0-36.1-34.8
	COP	kW / kW	3.61	
Temp. range of heating *4	Indoor temp.	D.B.	15 to 27degC(59 to 81degF)	
	Outdoor temp.	W.B.	-20 to 15.5degC(-4 to 60degF)	
Indoor unit connectable	Total capacity	50 to 150 % of outdoor unit capacity		
	Model / Quantity	P15 to P250 / 2 to 50 (Connectable branch pipe number is max. 48.)		
Noise level (measured in anechoic room)		dB <A>	62.5	
Diameter of refrigerant pipe	High pressure	mm(in.)	28.58(1-1/8") Brazed	
	Low pressure	mm(in.)	28.58(1-1/8") Brazed	

Set Model

Model			PURY-P300YHM-A(-BS)	PURY-P350YHM-A(-BS)
External finish			Pre-coated galvanized steel sheet (+powder coating for -BS type) <MUNSELL 5Y 8/1>	Pre-coated galvanized steel sheet (+powder coating for -BS type) <MUNSELL 5Y 8/1>
External dimension HxWxD	mm		1,710(1,650 without legs) x 920 x 760	1,710(1,650 without legs) x 1,220 x 760
	in.		67-3/8"(65" without legs) x 36-1/4" x 29-15/16"	67-3/8"(65" without legs) x 48-1/16" x 29-15/16"
Net weight	kg(lb)		240(530)	265(585)
Heat exchanger			Salt-resistant cross fin & copper tube	
Compressor	Type		Inverter scroll hermetic compressor	
	Maker		AC&R Works, MITSUBISHI ELECTRIC CORPORATION	
	Starting method		Inverter	
	Motor output	kW	8.2	10.3
	Case heater	kW	0.045(240 V)	0.045(240 V)
	Lubricant		MEL32	
FAN	Air flow rate	m ³ / min	185	225
		L/s	3,083	3,750
		cfm	6,532	7,945
	External static press.		0 - 30 - 60Pa	
	Type x Quantity		Propeller fan x 1	
	Control, Driving mechanism		Inverter-control, Direct-driven by motor	
Motor output	kW	0.92	0.92	
HIC circuit (HIC: Heat Inter-Changer)				
Protection	High pressure protection		High pressure sensor, High pressure switch at 4.15MPa (601 psi)	High pressure sensor, High pressure switch at 4.15MPa (601 psi)
	Inverter circuit (COMP. / FAN)		Over-heat protection, Over-current protection	Over-heat protection, Over-current protection
	Compressor		Over-heat protection, Over-current protection	Over-heat protection, Over-current protection
	Fan motor		Thermal switch	Thermal switch
Defrosting method				
Auto-defrost mode (Reversed refrigerant circle)				
Refrigerant	Type x original charge		R410A x 10.5kg (24lb)	R410A x 13.0kg (29lb)
	Control		Indoor LEV and BC controller	
Pipe between unit and distributor	High pressure	mm(in.)	19.05(3/4")Brazed	19.05(3/4")Brazed
	Low pressure	mm(in.)	22.22(7/8")Brazed	28.58(1-1/8")Brazed
Drawing	External		WKB94G550	
	Wiring		WKE94C141	
Standard attachment	Document		Installation Manual	
	Accessory		Details refer to External Drw	
Optional parts			Outdoor Twinning kit: CMY-R100VBK joint: CMY-Y102S-G2, CMY-Y102L-G2, CMY-Y202-G2, CMY-R160-J Main BC controller: CMB-P108, 1010, 1013, 1016V-GA Sub BC controller: CMB-P104, 108V-GB, CMB-P1016V-HB	
Remark			Details on foundation work, duct work, insulation work, electrical wiring, power source switch, and other items shall be referred to the Installation Manual. Systems with considerably long pipe runs, in heating mode, may be subject to slightly louder than normal noise from the outdoor unit/s. The outdoor twinning kit(low pressure) should be connected to the low pressure side of the outdoor unit. If the connected units are of different capacities, the outdoor twinning kit(low pressure) should be installed in the unit with the largest capacity.	

Note :	*1 Nominal cooling conditions	*2 Nominal cooling conditions	*3 Nominal heating conditions	Unit converter
Indoor :	27degCDB/19degCWB (81degFDB/66degFWB)	27degCDB/19.5degCWB (81degFDB/67degFWB)	20degCDB (68degFDB)	kcal =kW x 860
Outdoor :	35degCDB (95degFDB)	35degCDB (95degFDB)	7degCDB/6degCWB (45degFDB/43degFWB)	Btu/h =kW x 3,412
Pipe length :	7.5m(24-9/16"ft.)	5m(16-3/8"ft.)	7.5m(24-9/16"ft.)	cfm =m ³ /min x 35.31
Level difference :	0m(0ft.)	0m(0ft.)	0m(0ft.)	lb =kg / 0.4536
*4 -5degC(23degF)DB/-6degC(21degF)WB to 21degC(70degF)DB/15.5degC(60degF)WB with cooling/heating mixed operation.				
* Nominal condition *1, *3 are subject to JIS B8615-1				
* Due to continuing improvement, above specifications may be subject to change without notice.				
				*Above specification data is subject to rounding variation.

Ref.:PURY_YHM-A_SPC_EUDB_P650_56

1. SPECIFICATIONS

Model			PURY-P700YSHM-A(-BS)
Power source			3-phase 4-wire 380-400-415V 50/60Hz
Cooling capacity (Nominal)	*1	kW	80.0
	*1	kcal / h	68,800
	*1	Btu / h	273,000
	*2	kcal / h	70,000
	Power input	kW	24.72
	Current input	A	41.7-39.6-38.2
	COP	kW / kW	3.23
Temp. range of cooling *4	Indoor	W.B.	15 to 24degC(59 to 75degF)
	Outdoor	D.B.	-5 to 43degC(23 to 109degF)
Heating capacity (Nominal)	*3	kW	88.0
	*3	kcal / h	75,700
	*3	Btu / h	300,300
	Power input	kW	24.30
	Current input	A	41.0-38.9-37.5
	COP	kW / kW	3.62
Temp. range of heating *4	Indoor temp.	D.B.	15 to 27degC(59 to 81degF)
	Outdoor temp.	W.B.	-20 to 15.5degC(-4 to 60degF)
Indoor unit connectable	Total capacity		50 to 150 % of outdoor unit capacity
	Model / Quantity		P15 to P250 / 2 to 50 (Connectable branch pipe number is max. 48.)
Noise level (measured in anechoic room)		dB <A>	63.0
Diameter of refrigerant pipe	High pressure	mm(in.)	28.58(1-1/8") Brazed
	Low pressure	mm(in.)	34.92(1-3/8") Brazed

Set Model

Model			PURY-P300YHM-A(-BS)	PURY-P400YHM-A(-BS)
External finish			Pre-coated galvanized steel sheet (+powder coating for -BS type) <MUNSELL 5Y 8/1>	Pre-coated galvanized steel sheet (+powder coating for -BS type) <MUNSELL 5Y 8/1>
External dimension HxWxD	mm		1,710(1,650 without legs) x 920 x 760	1,710(1,650 without legs) x 1,220 x 760
	in.		67-3/8"(65" without legs) x 36-1/4" x 29-15/16"	67-3/8"(65" without legs) x 48-1/16" x 29-15/16"
Net weight	kg(lb)		240(530)	265(585)
Heat exchanger			Salt-resistant cross fin & copper tube	
Compressor	Type		Inverter scroll hermetic compressor	
	Maker		AC&R Works, MITSUBISHI ELECTRIC CORPORATION	
	Starting method		Inverter	
	Motor output	kW	8.2	10.5
	Case heater	kW	0.045(240 V)	0.045(240 V)
	Lubricant		MEL32	
FAN	Air flow rate	m ³ / min	185	225
		L/s	3,083	3,750
		cfm	6,532	7,945
	External static press.		0 - 30 - 60Pa	
	Type x Quantity		Propeller fan x 1	
	Control, Driving mechanism		Inverter-control, Direct-driven by motor	
Motor output	kW	0.92	0.92	
HIC circuit (HIC: Heat Inter-Changer)			-	
Protection	High pressure protection		High pressure sensor, High pressure switch at 4.15MPa (601 psi)	
	Inverter circuit (COMP. / FAN)		Over-heat protection, Over-current protection	
	Compressor		Over-heat protection, Over-current protection	
	Fan motor		Thermal switch	
Defrosting method			Auto-defrost mode (Reversed refrigerant circle)	
Refrigerant	Type x original charge		R410A x 10.5kg (24lb)	R410A x 13.0kg (29lb)
	Control		Indoor LEV and BC controller	
Pipe between unit and distributor	High pressure	mm(in.)	19.05(3/4")Brazed	22.22(7/8")Brazed
	Low pressure	mm(in.)	22.22(7/8")Brazed	28.58(1-1/8")Brazed
Drawing	External		WKB94G550	
	Wiring		WKE94C141	
Standard attachment	Document		Installation Manual	
	Accessory		Details refer to External Drw	
Optional parts			Outdoor Twinning kit: CMY-R200VBK joint: CMY-Y102S-G2, CMY-Y102L-G2, CMY-Y202-G2, CMY-R160-J Main BC controller: CMB-P1016V-HA Sub BC controller: CMB-P104, 108V-GB, CMB-P1016V-HB	
Remark			Details on foundation work, duct work, insulation work, electrical wiring, power source switch, and other items shall be referred to the Installation Manual. Systems with considerably long pipe runs, in heating mode, may be subject to slightly louder than normal noise from the outdoor unit/s. The outdoor twinning kit(low pressure) should be connected to the low pressure side of the outdoor unit. If the connected units are of different capacities, the outdoor twinning kit(low pressure) should be installed in the unit with the largest capacity.	

Note :	*1 Nominal cooling conditions	*2 Nominal cooling conditions	*3 Nominal heating conditions	Unit converter
Indoor :	27degCDB/19degCWB (81degFDB/66degFWB)	27degCDB/19.5degCWB (81degFDB/67degFWB)	20degCDB (68degFDB)	kcal =kW x 860
Outdoor :	35degCDB (95degFDB)	35degCDB (95degFDB)	7degCDB/6degCWB (45degFDB/43degFWB)	Btu/h =kW x 3,412
Pipe length :	7.5m(24-9/16"ft.)	5m(16-3/8"ft.)	7.5m(24-9/16"ft.)	cfm =m ³ /min x 35.31
Level difference :	0m(0ft.)	0m(0ft.)	0m(0ft.)	lb =kg / 0.4536
*4 -5degC(23degF)DB/-6degC(21degF)WB to 21degC(70degF)DB/15.5degC(60degF)WB with cooling/heating mixed operation.				
* Nominal condition *1, *3 are subject to JIS B8615-1				
* Due to continuing improvement, above specifications may be subject to change withoutnotice.				
				*Above specification data is subject to rounding variation.

Model			PURY-P750YSHM-A(-BS)	
Power source	3-phase 4-wire 380-400-415V 50/60Hz			
Cooling capacity (Nominal)	*1	kW	85.0	
	*1	kcal / h	73,100	
	*1	Btu / h	290,000	
	*2	kcal / h	75,000	
	Power input	kW	27.86	
Current input	A	47.0-44.6-43.0		
COP	kW / kW		3.05	
Temp. range of cooling *4	Indoor	W.B.	15 to 24degC(59 to 75degF)	
	Outdoor	D.B.	-5 to 43degC(23 to 109degF)	
Heating capacity (Nominal)	*3	kW	95.0	
	*3	kcal / h	81,700	
	*3	Btu / h	324,100	
	Power input	kW	26.36	
	Current input	A	44.4-42.2-40.7	
COP	kW / kW		3.60	
Temp. range of heating *4	Indoor temp.	D.B.	15 to 27degC(59 to 81degF)	
	Outdoor temp.	W.B.	-20 to 15.5degC(-4 to 60degF)	
Indoor unit connectable	Total capacity	50 to 150 % of outdoor unit capacity		
	Model / Quantity	P15 to P250 / 2 to 50 (Connectable branch pipe number is max. 48.)		
Noise level (measured in anechoic room)		dB <A>	63.5	
Diameter of refrigerant pipe	High pressure	mm(in.)	28.58(1-1/8") Brazed	
	Low pressure	mm(in.)	34.92(1-3/8") Brazed	

Set Model			PURY-P350YHM-A(-BS)		PURY-P400YHM-A(-BS)	
External finish			Pre-coated galvanized steel sheet (+powder coating for -BS type) <MUNSELL 5Y 8/1>		Pre-coated galvanized steel sheet (+powder coating for -BS type) <MUNSELL 5Y 8/1>	
External dimension HxWxD	mm	1,710(1,650 without legs) x 1,220 x 760		1,710(1,650 without legs) x 1,220 x 760		
	in.	67-3/8"(65" without legs) x 48-1/16" x 29-15/16"		67-3/8"(65" without legs) x 48-1/16" x 29-15/16"		
Net weight	kg(lb)	265(585)		265(585)		
Heat exchanger			Salt-resistant cross fin & copper tube		Salt-resistant cross fin & copper tube	
Compressor	Type	Inverter scroll hermetic compressor		Inverter scroll hermetic compressor		
	Maker	AC&R Works, MITSUBISHI ELECTRIC CORPORATION		AC&R Works, MITSUBISHI ELECTRIC CORPORATION		
	Starting method	Inverter		Inverter		
	Motor output	kW	10.3		10.5	
	Case heater	kW	0.045(240 V)		0.045(240 V)	
	Lubricant	MEL32		MEL32		
FAN	Air flow rate	m ³ / min	225		225	
		L/s	3,750		3,750	
		cfm	7,945		7,945	
	External static press.	0 - 30 - 60Pa		0 - 30 - 60Pa		
	Type x Quantity	Propeller fan x 1		Propeller fan x 1		
	Control, Driving mechanism	Inverter-control, Direct-driven by motor		Inverter-control, Direct-driven by motor		
	Motor output	kW	0.92		0.92	
HIC circuit (HIC: Heat Inter-Changer)			-		-	
Protection	High pressure protection	High pressure sensor, High pressure switch at 4.15MPa (601 psi)		High pressure sensor, High pressure switch at 4.15MPa (601 psi)		
	Inverter circuit (COMP. / FAN)	Over-heat protection, Over-current protection		Over-heat protection, Over-current protection		
	Compressor	Over-heat protection, Over-current protection		Over-heat protection, Over-current protection		
	Fan motor	Thermal switch		Thermal switch		
Defrosting method			Auto-defrost mode (Reversed refrigerant circle)			
Refrigerant	Type x original charge	R410A x 13.0kg (29lb)		R410A x 13.0kg (29lb)		
	Control	Indoor LEV and BC controller				
Pipe between unit and distributor	High pressure	mm(in.)	19.05(3/4")Brazed		22.22(7/8")Brazed	
	Low pressure	mm(in.)	28.58(1-1/8")Brazed		28.58(1-1/8")Brazed	
Drawing	External	WKB94G551				
	Wiring	WKE94C141				
Standard attachment	Document	Installation Manual				
	Accessory	Details refer to External Drw				
Optional parts	Outdoor Twinning kit: CMY-R200VBK joint: CMY-Y102S-G2, CMY-Y102L-G2, CMY-Y202-G2, CMY-R160-J Main BC controller: CMB-P1016V-HA Sub BC controller: CMB-P104, 108V-GB, CMB-P1016V-HB					
Remark	Details on foundation work, duct work, insulation work, electrical wiring, power source switch, and other items shall be referred to the Installation Manual. Systems with considerably long pipe runs, in heating mode, may be subject to slightly louder than normal noise from the outdoor unit/s. The outdoor twinning kit(low pressure) should be connected to the low pressure side of the outdoor unit. If the connected units are of different capacities, the outdoor twinning kit(low pressure) should be installed in the unit with the largest capacity.					

Note :	*1 Nominal cooling conditions	*2 Nominal cooling conditions	*3 Nominal heating conditions	Unit converter
Indoor :	27degCDB/19degCWB (81degFDB/66degFWB)	27degCDB/19.5degCWB (81degFDB/67degFWB)	20degCDB (68degFDB)	kcal =kW x 860
Outdoor :	35degCDB (95degFDB)	35degCDB (95degFDB)	7degCDB/6degCWB (45degFDB/43degFWB)	Btu/h =kW x 3,412
Pipe length :	7.5m(24-9/16"ft.)	5m(16-3/8"ft.)	7.5m(24-9/16"ft.)	cfm =m ³ /min x 35.31
Level difference :	0m(0ft.)	0m(0ft.)	0m(0ft.)	lb =kg / 0.4536
*4 -5degC(23degF)DB/-6degC(21degF)WB to 21degC(70degF)DB/15.5degC(60degF)WB with cooling/heating mixed operation.				
* Nominal condition *1, *3 are subject to JIS B8615-1				
* Due to continuing improvement, above specifications may be subject to change without notice.				
				*Above specification data is subject to rounding variation.

Ref.:PURY_YHM-A_SPC_EUDB_P750_56

1. SPECIFICATIONS

Model			PURY-P800YSHM-A(-BS)
Power source			3-phase 4-wire 380-400-415V 50/60Hz
Cooling capacity (Nominal)	*1	kW	90.0
	*1	kcal / h	77,400
	*1	Btu / h	307,100
	*2	kcal / h	80,000
	Power input	kW	29.75
	Current input	A	50.2-47.7-45.9
COP			3.02
Temp. range of cooling *4	Indoor	W.B.	15 to 24degC(59 to 75degF)
	Outdoor	D.B.	-5 to 43degC(23 to 109degF)
Heating capacity (Nominal)	*3	kW	100.0
	*3	kcal / h	86,000
	*3	Btu / h	341,200
	Power input	kW	27.64
	Current input	A	46.6-44.3-42.7
	COP		
Temp. range of heating *4	Indoor temp.	D.B.	15 to 27degC(59 to 81degF)
	Outdoor temp.	W.B.	-20 to 15.5degC(-4 to 60degF)
Indoor unit connectable	Total capacity	50 to 150 % of outdoor unit capacity	
	Model / Quantity	P15 to P250 / 2 to 50 (Connectable branch pipe number is max. 48.)	
Noise level (measured in anechoic room)		dB <A>	64.0
Diameter of refrigerant pipe	High pressure	mm(in.)	28.58(1-1/8") Braze
	Low pressure	mm(in.)	34.92(1-3/8") Braze

Set Model

Model			PURY-P400YHM-A(-BS)	PURY-P400YHM-A(-BS)
External finish			Pre-coated galvanized steel sheet (+powder coating for -BS type) <MUNSELL 5Y 8/1>	Pre-coated galvanized steel sheet (+powder coating for -BS type) <MUNSELL 5Y 8/1>
External dimension HxWxD	mm		1,710(1,650 without legs) x 1,220 x 760	1,710(1,650 without legs) x 1,220 x 760
	in.		67-3/8"(65" without legs) x 48-1/16" x 29-15/16"	67-3/8"(65" without legs) x 48-1/16" x 29-15/16"
Net weight		kg(lb)	265(585)	265(585)
Heat exchanger			Salt-resistant cross fin & copper tube	
Compressor	Type		Inverter scroll hermetic compressor	
	Maker		AC&R Works, MITSUBISHI ELECTRIC CORPORATION	
	Starting method		Inverter	
	Motor output	kW	10.5	
	Case heater	kW	0.045(240 V)	
	Lubricant		MEL32	
FAN	Air flow rate	m ³ / min	225	
		L/s	3,750	
		cfm	7,945	
	External static press.		0 - 30 - 60Pa	
	Type x Quantity		Propeller fan x 1	
	Control, Driving mechanism		Inverter-control, Direct-driven by motor	
Motor output	kW	0.92		
HIC circuit (HIC: Heat Inter-Changer)			-	
Protection	High pressure protection		High pressure sensor, High pressure switch at 4.15MPa (601 psi)	
	Inverter circuit (COMP. / FAN)		Over-heat protection, Over-current protection	
	Compressor		Over-heat protection, Over-current protection	
	Fan motor		Thermal switch	
Defrosting method			Auto-defrost mode (Reversed refrigerant circle)	
Refrigerant	Type x original charge		R410A x 13.0kg (29lb)	R410A x 13.0kg (29lb)
	Control		Indoor LEV and BC controller	
Pipe between unit and distributor	High pressure	mm(in.)	22.22(7/8")Braze	
	Low pressure	mm(in.)	28.58(1-1/8")Braze	
Drawing	External		WKB94G551	
	Wiring		WKE94C141	
Standard attachment	Document		Installation Manual	
	Accessory		Details refer to External Drw	
Optional parts			Outdoor Twinning kit: CMY-R200VBK joint: CMY-Y102S-G2, CMY-Y102L-G2, CMY-Y202-G2, CMY-R160-J Main BC controller: CMB-P1016V-HA Sub BC controller: CMB-P104, 108V-GB, CMB-P1016V-HB	
Remark			Details on foundation work, duct work, insulation work, electrical wiring, power source switch, and other items shall be referred to the Installation Manual. Systems with considerably long pipe runs, in heating mode, may be subject to slightly louder than normal noise from the outdoor unit/s. The outdoor twinning kit(low pressure) should be connected to the low pressure side of the outdoor unit. If the connected units are of different capacities, the outdoor twinning kit(low pressure) should be installed in the unit with the largest capacity.	

Note :	*1 Nominal cooling conditions	*2 Nominal cooling conditions	*3 Nominal heating conditions	Unit converter
Indoor :	27degCDB/19degCWB (81degFDB/66degFWB)	27degCDB/19.5degCWB (81degFDB/67degFWB)	20degCDB (68degFDB)	kcal =kW x 860
Outdoor :	35degCDB (95degFDB)	35degCDB (95degFDB)	7degCDB/6degCWB (45degFDB/43degFWB)	Btu/h =kW x 3,412
Pipe length :	7.5m(24-9/16"ft.)	5m(16-3/8"ft.)	7.5m(24-9/16"ft.)	cfm =m ³ /min x 35.31
Level difference :	0m(0ft.)	0m(0ft.)	0m(0ft.)	lb =kg / 0.4536
*4 -5degC(23degF)DB/-6degC(21degF)WB to 21degC(70degF)DB/15.5degC(60degF)WB with cooling/heating mixed operation.				
* Nominal condition *1, *3 are subject to JIS B8615-1				
* Due to continuing improvement, above specifications may be subject to change withoutnotice.				
				*Above specification data is subject to rounding variation.

PURY-P250,300YHM-A(-BS)

Ref. : PURY_YHM-A_EXD_EUDB_P250-P300_R1
Unit : mm

- <Accessories>
- Connecting pipe
- <Low pressure> • Pipe (ID ϕ 25.4X(D ϕ 22.2)...P250,P300 1 pc.

Note 1. Please refer to (2/2) for information regarding necessary spacing around the unit and foundation work.
2. The detachable leg can be removed at site.
3. At brazing of pipes, wrap the refrigerant service valve with wet cloth and keep the temperature of refrigerant service valve under 120°C.

NO.	Usage	Specifications
①	Front through hole	140X77 Knockout hole
②	For pipes	Front through hole (Uses when twinning kit (optional parts) is mounted.)
③	Bottom through hole	150X92 Knockout hole
④	Front through hole	ϕ 65 or ϕ 40 Knockout hole
⑤	For wires	Front through hole
⑥	Bottom through hole	ϕ 52 or ϕ 27 Knockout hole
⑦	For transmission cables	Front through hole
⑦	Front through hole	ϕ 34 Knockout hole

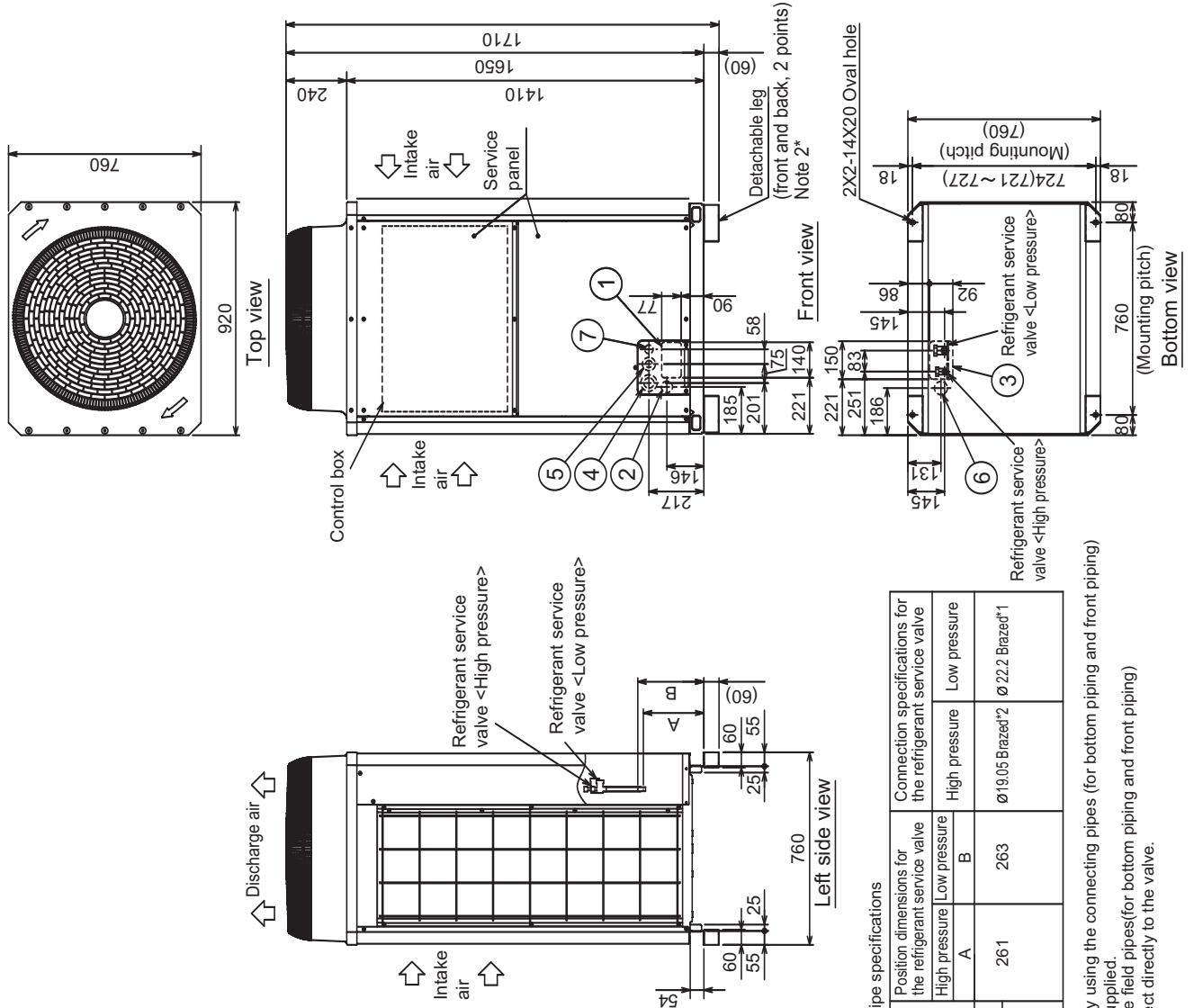

Connecting pipe specifications

Model	Position dimensions for the refrigerant service valve		Connection specifications for the refrigerant service valve	
	High pressure	Low pressure	High pressure	Low pressure
PURY-P250YHM	A	B		
PURY-P300YHM	261	263	ϕ 19.05 Brazed*2	ϕ 22.2 Brazed*1

*1. Connect by using the connecting pipes (for bottom piping and front piping) that are supplied.
*2. Expand the field pipes (for bottom piping and front piping) and connect directly to the valve.

PURY-P250,300YHM-A(-BS)

Ref. : PURY_YHM-A_EXD_EUDB_P250-P300_R2
Unit : mm

1. Required space around the unit

In case of single installation

- ① Secure enough space around the unit as shown in the figure below.
- With a space of at least 300mm to the wall on the back of the unit

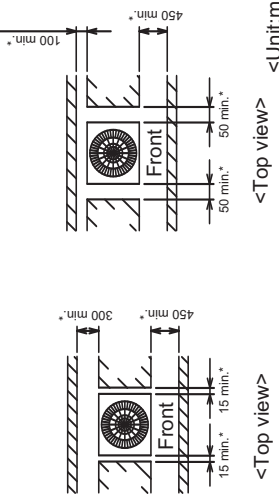

In case of collective installation

- ① When multiple units are installed adjacent to each other, secure enough space to allow for air circulation and walkway between groups of units as shown in the figures below.
- ② At least two sides must be left open.
- ③ As with the single installation, add the height that exceeds the height limit <h> to the figures that are marked with an asterisk.

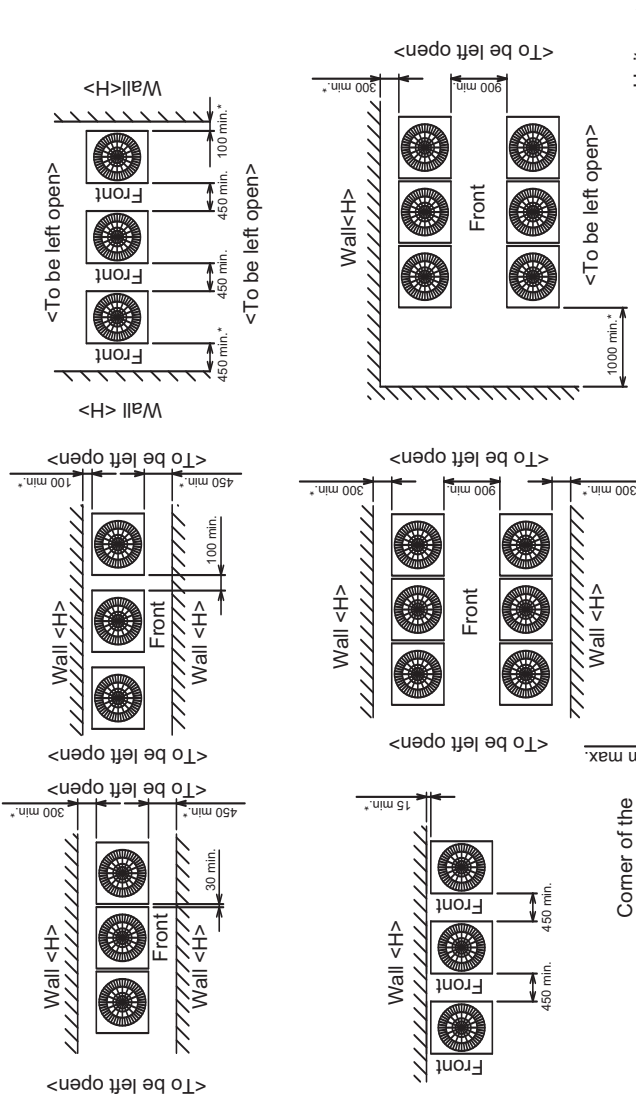

- ② When the height of the walls on the front, back or on the sides <H> exceeds the wall height limit as defined below add the height that exceeds the height limit <h> to the figures that are marked with an asterisk.

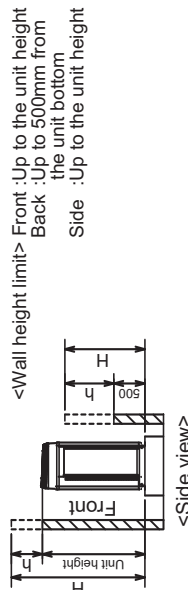

2. Foundation work

- ① Take into consideration the surface strength, water drainage route, piping route, and wiring route when preparing the installation site.
<Note that the drain water comes out of the unit during operation.>
- ② Build the foundation in such way that the corner of the installation leg is securely supported as shown in the right figure. (Fig.A,B)
When using cushion pads, be sure that the full width of the unit is covered.
- ③ The protrusion length of the anchor bolt must not exceed 30mm. (Fig.A,B)
- ④ Use four fixing plates as shown in the right figure <field supply required> when using post-installed anchor bolts. (Fig.C,D)
- ⑤ To prevent small animals and water from entering the unit and damaging its parts, close the gap around the edges of through holes for pipes and wires with filler plates <field supply required>.
- ⑥ When the pipes or cables are routed at the bottom of the unit, make sure that the through hole at the base of the unit does not get blocked with the installation base.
- ⑦ Refer to the Installation Manual when installing units on an installation base.

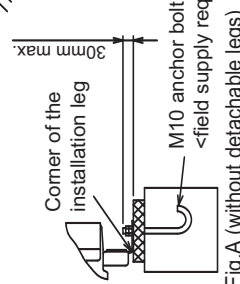

Fig.A (without detachable legs)

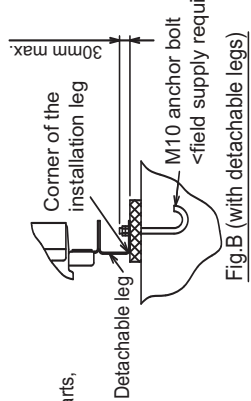

Fig.B (with detachable legs)

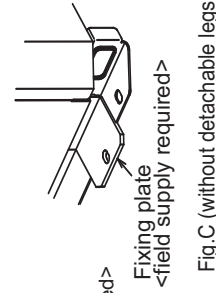

Fig.C (without detachable legs)

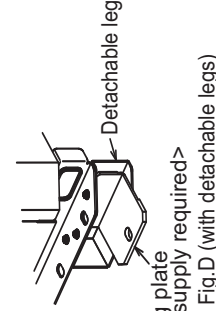

Fig.D (with detachable legs)

PURY-P350,400YHM-A(-BS)

Ref. : PURY_YHM-A_EXD_EUDB_P350-P400_R1
Unit : mm

- <Accessories>
- Connecting pipe
 - <Low pressure>
 - Pipe (IDø25.4XIDø28.58).....P350,P400 1 pc.
 - Pipe (IDø25.4XODø19.05).....P350 1 pc.
 - <High pressure>
 - Elbow (IDø19.05XODø19.05).....P350 1 pc.
 - Pipe (IDø25.4XIDø22.2).....P400 1 pc.

Note 1. Please refer to (2/2) for information regarding necessary spacing around the unit and foundation work.
 2. The detachable leg can be removed at site.
 3. At brazing of pipes, wrap the refrigerant service valve with wet cloth and keep the temperature of refrigerant service valve under 120°C.

NO.	Usage	Specifications
①	Front through hole	140X77 Knockout hole
②	For pipes	Front through hole (Uses when wiring kit (optional parts) is mounted.)
③	Bottom through hole	150X94 Knockout hole
④	For wires	Front through hole
⑤	Bottom through hole	Ø65 or Ø40 Knockout hole
⑥	For transmission cables	Bottom through hole
⑦	Front through hole	Ø65 Knockout hole
⑧	Front through hole	Ø34 Knockout hole

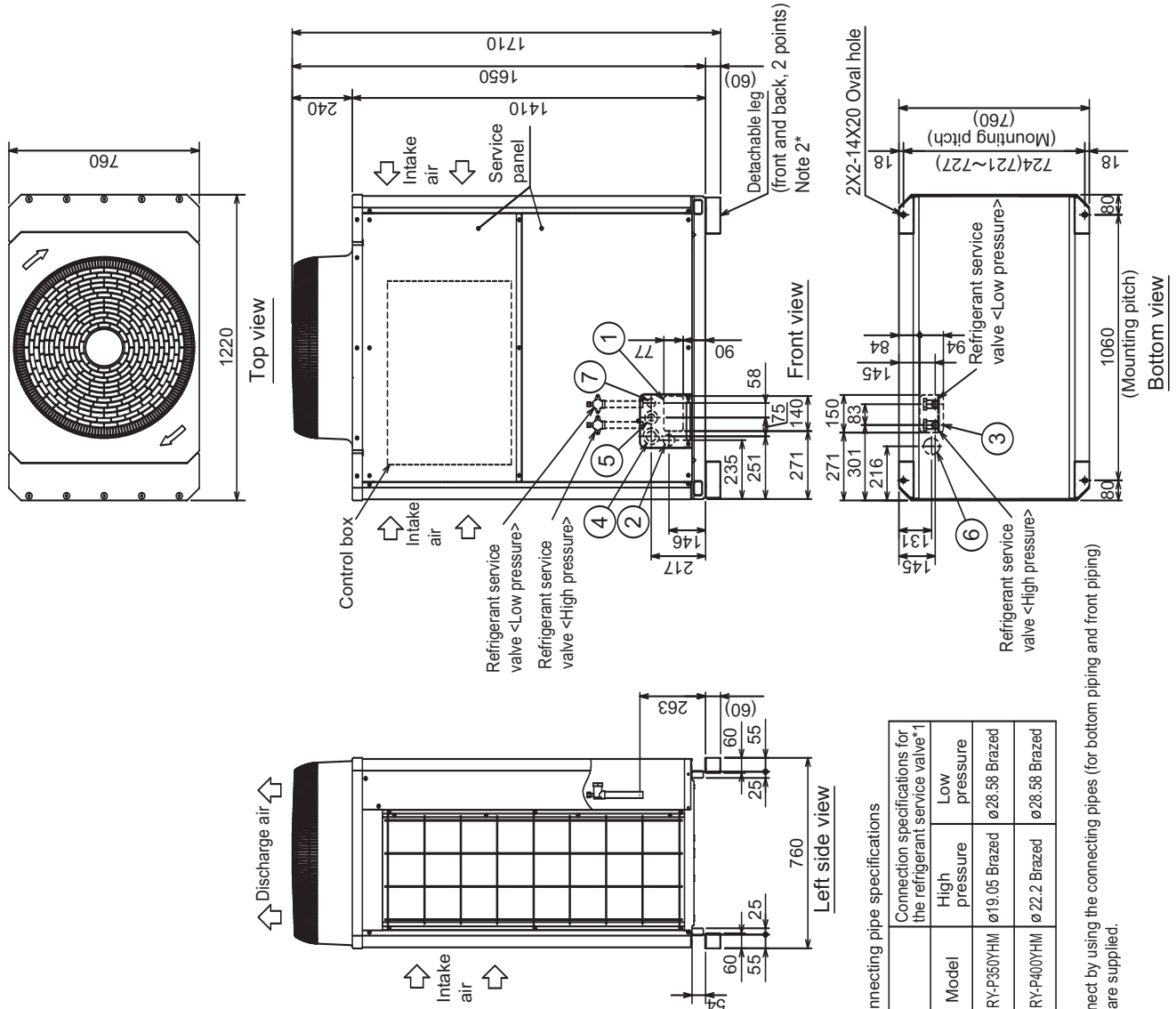

Connecting pipe specifications

Model	High pressure	Low pressure
PURY-P350YHM	ø19.05 Braze	ø28.58 Braze
PURY-P400YHM	ø22.2 Braze	ø28.58 Braze

*1. Connect by using the connecting pipes (for bottom piping and front piping) that are supplied.

PURY-P350,400YHM-A-(BS)

Ref. : PURY_YHM-A_EXD_EUDB_P350-P400_R2
Unit : mm

1. Required space around the unit

In case of single installation

- ① Secure enough space around the unit as shown in the figure below.
- With a space of at least 300mm to the wall on the back of the unit

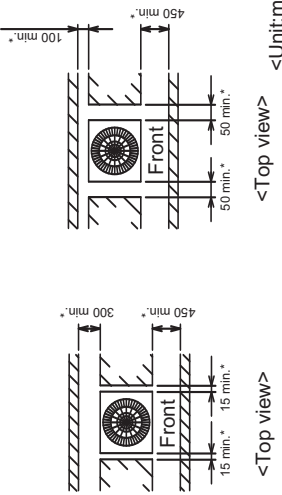

- ② When the height of the walls on the front, back or on the sides <H> exceeds the wall height limit as defined below add the height that exceeds the height limit <h> to the figures that are marked with an asterisk.

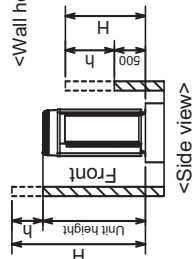

- <Wall height limit> Front :Up to the unit height
- Back :Up to 500mm from the unit bottom
- Side :Up to the unit height

In case of collective installation

- ① When multiple units are installed adjacent to each other, secure enough space to allow for air circulation and walkway between groups of units as shown in the figures below.
- ② At least two sides must be left open.
- ③ As with the single installation, add the height that exceeds the height limit <h> to the figures that are marked with an asterisk.

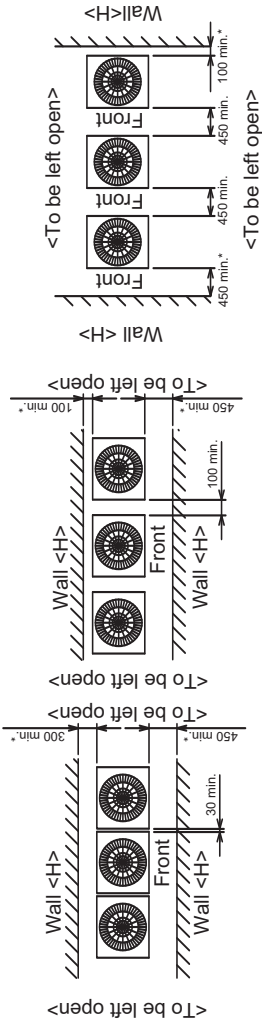

- <Top view> <Unit:mm>

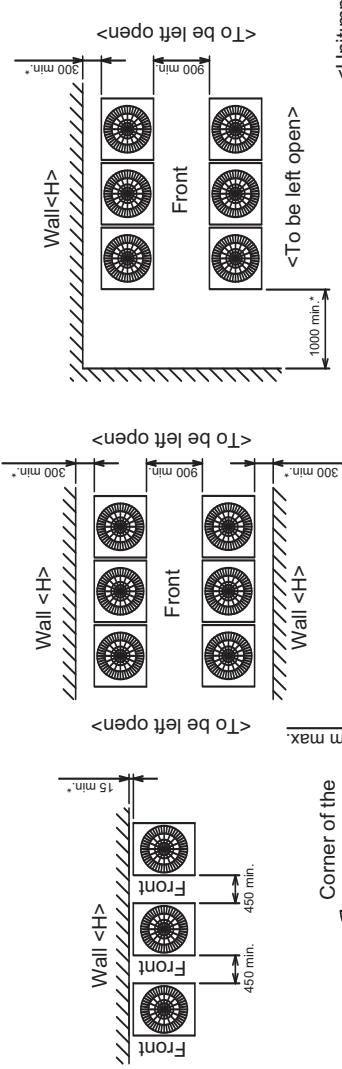

2. Foundation work

- ① Take into consideration the surface strength, water drainage route, piping route, and wiring route when preparing the installation site.
- ② Build the foundation in such way that the corner of the installation leg is securely supported as shown in the right figure. (Fig.A,B)
- ③ When using cushion pads, be sure that the full width of the unit is covered.
- ④ The protrusion length of the anchor bolt must not exceed 30mm. (Fig.A,B)
- ⑤ Use four fixing plates as shown in the right figure <field supply required> when using post-installed anchor bolts. (Fig.C,D)
- ⑥ To prevent small animals and water from entering the unit and damaging its parts, close the gap around the edges of through holes for pipes and wires with filler plates <field supply required>
- ⑦ When the pipes or cables are routed at the bottom of the unit, make sure that the through hole at the base of the unit does not get blocked with the installation base.
- ⑧ Refer to the Installation Manual when installing units on an installation base.

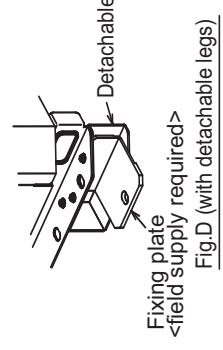
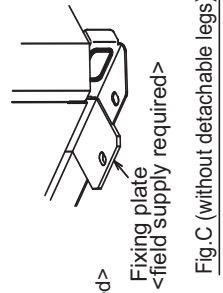
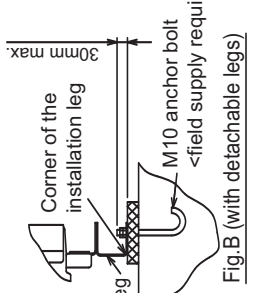
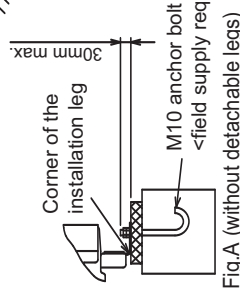

PURY-P500,550,600YSHM-A(-BS)

Ref. : PURY_YHM-A_EXD_EUDB_P500-P600
Unit : mm

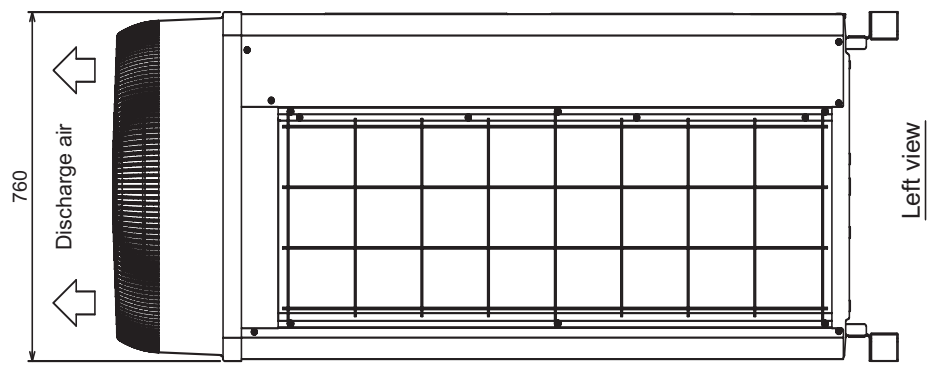
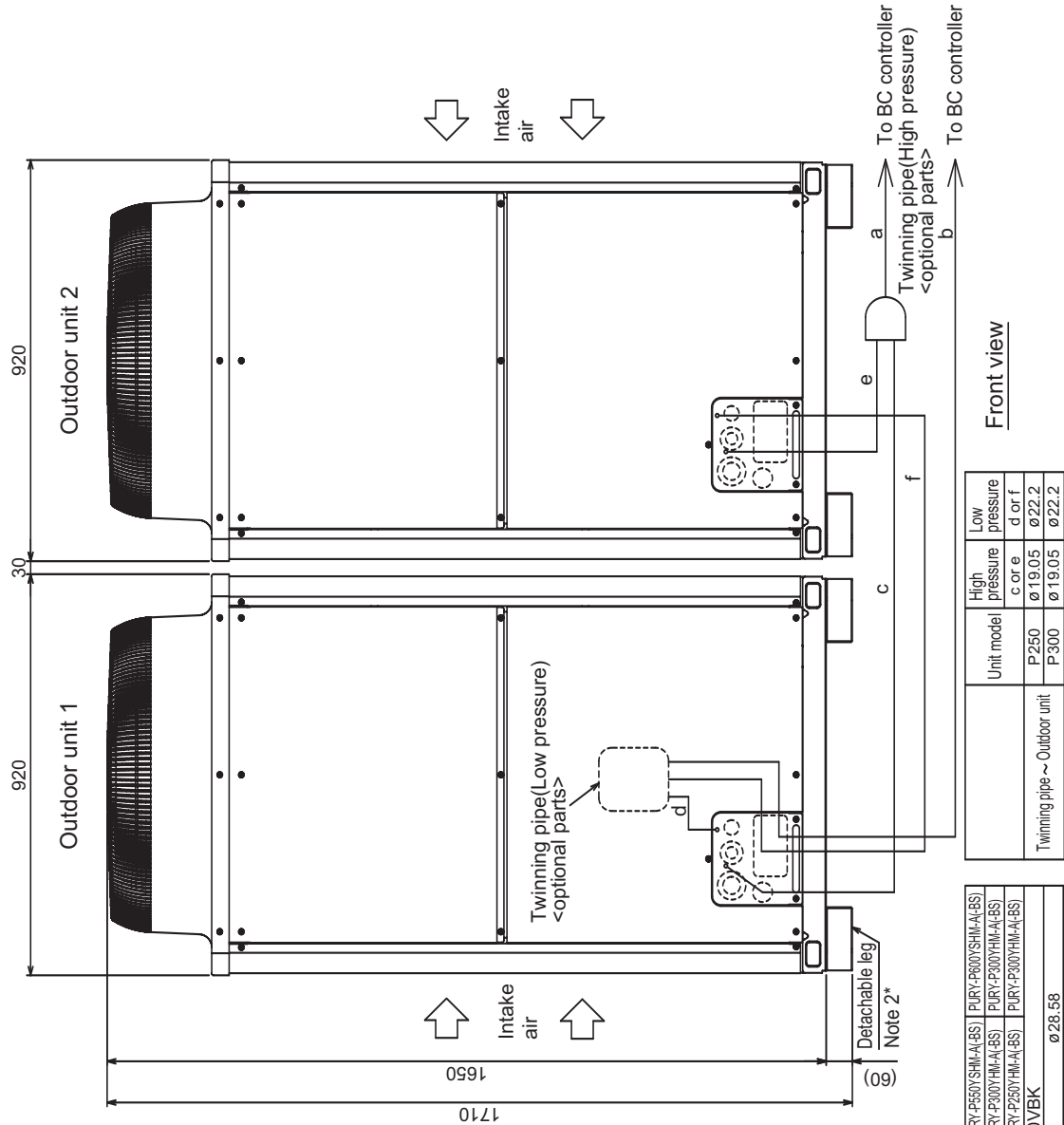

Front view

Unit model	High pressure core	Low pressure diameter
P250	ø19.05	ø22.2
P300	ø19.05	ø22.2

Twinning pipe ~ Outdoor unit

Twinning pipe connection size

Package unit name	PURY-P500YSHM-A(-BS)	PURY-P550YSHM-A(-BS)	PURY-P600YSHM-A(-BS)
Outdoor unit 1	PURY-P250YHM-A(-BS)	PURY-P250YHM-A(-BS)	PURY-P300YHM-A(-BS)
Outdoor unit 2	PURY-P250YHM-A(-BS)	PURY-P250YHM-A(-BS)	PURY-P300YHM-A(-BS)
Outdoor Twinning Kit (optional parts)	CMY-R100V/BK		
BC controller ~ Twinning pipe	ø22.2	ø28.58	ø28.58
High pressure	a		
Low pressure	b		

- Note 1. Connect the pipes as shown in the figure above. Refer to the table above for the pipe size.
 Note 2. The detachable leg can be removed at site.
 3. Twinning pipe (High pressure) should not be tilted more than 15 degrees from the ground.
 4. See the Installation Manual for the details of Twinning pipe installation.

PURY-P650,700YSHM-A(-BS)

Ref. : PURY_YHM-A_EXD_EUDB_P650-P700
Unit : mm

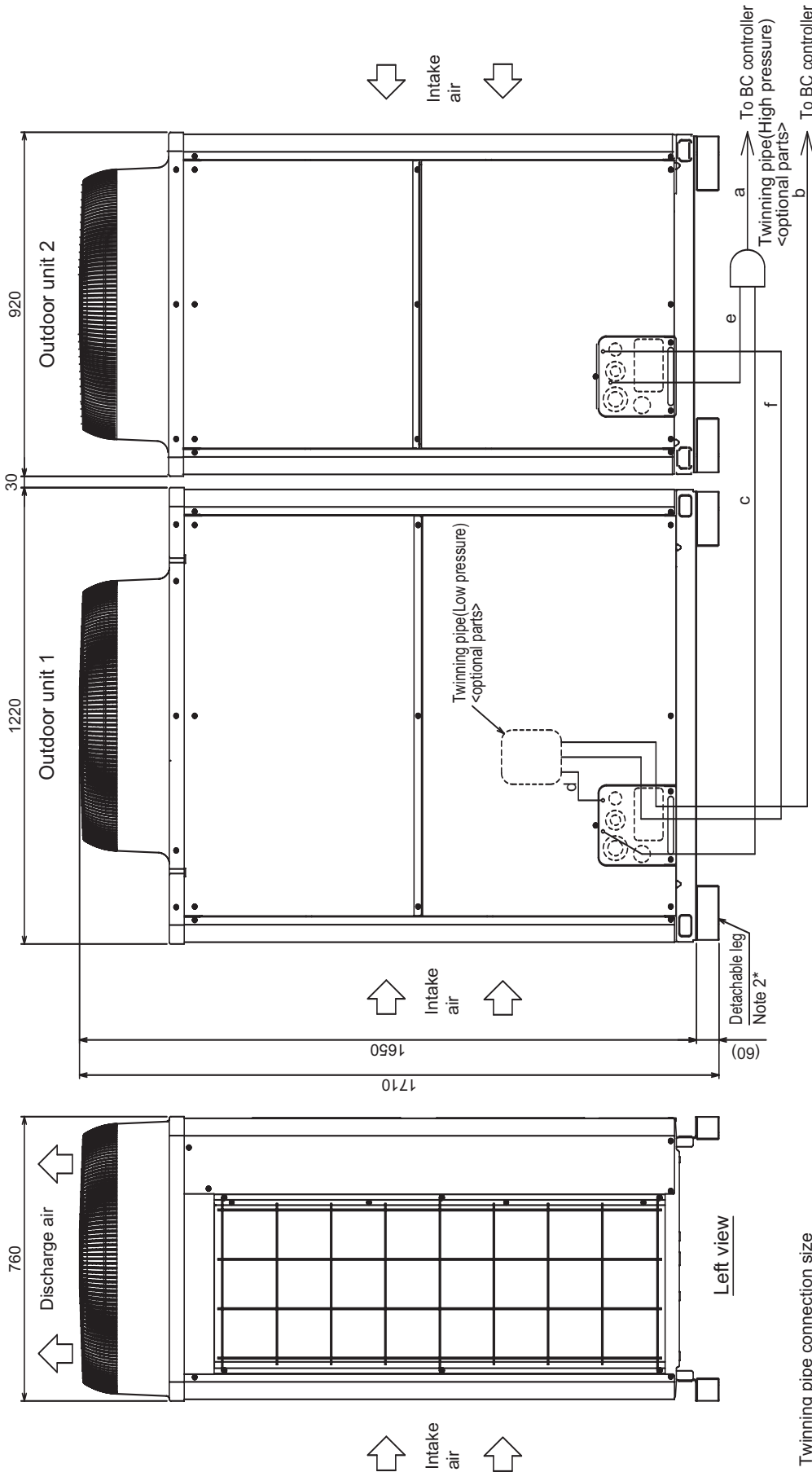

Front view

Twinning pipe~Outdoor unit	Unit model	High pressure	Low pressure
		c or e ø19.05 ø22.2	d or f ø19.05 ø28.58
	P300	ø19.05 ø22.2	ø19.05 ø28.58
	P350	ø19.05 ø22.2	ø19.05 ø28.58
	P400	ø22.2 ø28.58	ø22.2 ø28.58

Twinning pipe connection size	Package unit name	
	High pressure	PURY-P650YSHM-A(-BS) PURY-P700YSHM-A(-BS)
Low pressure	PURY-P350YHM-A(-BS) PURY-P400YHM-A(-BS)	
	PURY-P300YHM-A(-BS) PURY-P300YHM-A(-BS)	
	CMY-R100VBK CMY-R200VBK	
	ø28.58	
	ø28.58	
	ø34.93	

- Note 1. Connect the pipes as shown in the figure above. Refer to the table above for the pipe size.
 2. The detachable leg can be removed at site.
 3. Twinning pipe (High pressure) should not be tilted more than 15 degrees from the ground.
 4. See the Installation Manual for the details of Twinning pipe installation.

PURY-P750,800YSHM-A(-BS)

Ref. : PURY_YHM-A_EXD_EUDB_P750-P800
Unit : mm

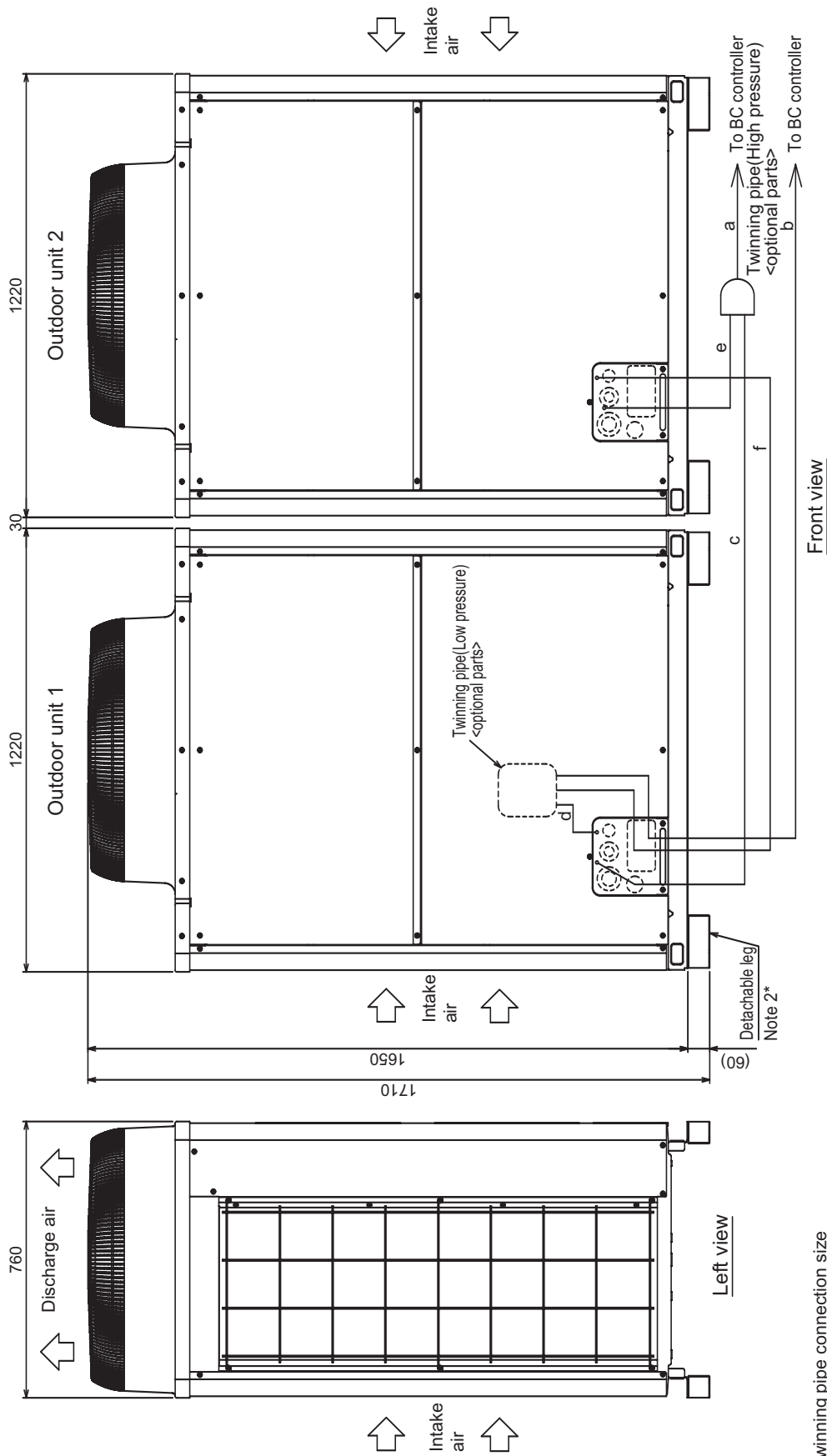

Front view

Left view

Twinning pipe connection size

Package unit name	PURY-P750YSHM-A(-BS)	PURY-P800YSHM-A(-BS)	Unit model	High pressure	Low pressure
Outdoor unit 1	PURY-P400YHM-A(-BS)	PURY-P400YHM-A(-BS)	P350	c or e	d or f
Outdoor unit 2	PURY-P300YHM-A(-BS)	PURY-P400YHM-A(-BS)	P400	ø19.05	ø28.58
Outdoor Twinning Kit(optional parts)	CMY-R200VBK			ø22.2	ø28.58
BC controller ~ Twinning pipe	High pressure	a			
	Low pressure	b			

- Note 1. Connect the pipes as shown in the figure above. Refer to the table above for the pipe size.
 2. The detachable leg can be removed at site.
 3. Twinning pipe (High pressure) should not be tilted more than 15 degrees from the ground.
 4. See the Installation Manual for the details of Twinning pipe installation.

3. CENTER OF GRAVITY

PURY-P250, P300, EP200YHM-A (-BS)

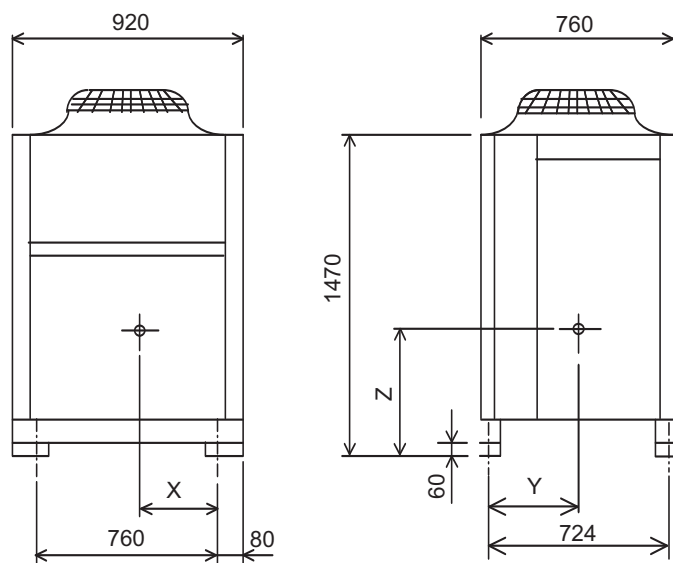

Model	X	Y	Z
PURY-P250YHM-A (-BS)	345	332	655
PURY-P300YHM-A (-BS)	335	327	645
PURY-EP200YHM-A (-BS)	345	332	655

PURY-P350, P400, EP300YHM-A (-BS)

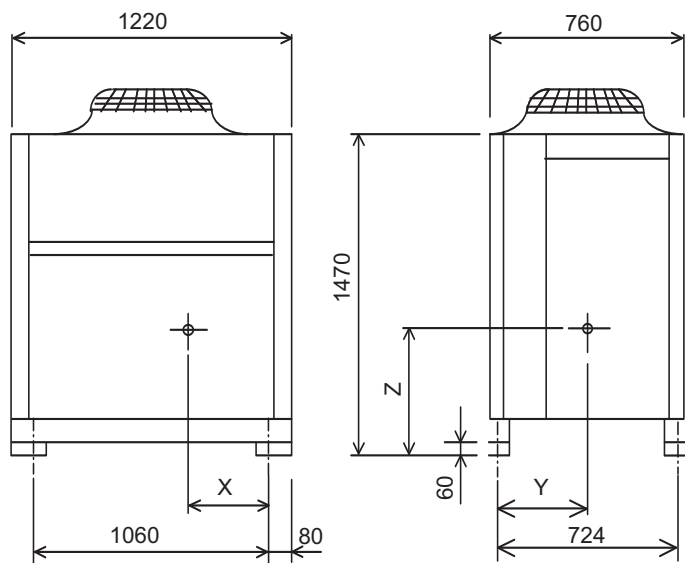

Model	X	Y	Z
PURY-P350YHM-A (-BS)	450	322	630
PURY-P400YHM-A (-BS)	450	322	630
PURY-EP300YHM-A (-BS)	450	322	630

Ref. : PURY_YHM-A_COG_EUDB_ALL

PURY-EP200,(E)P250,300,350,400YHM-A(-BS)

Ref.:PURY_YHM-A_EWD_EUDB_ALL

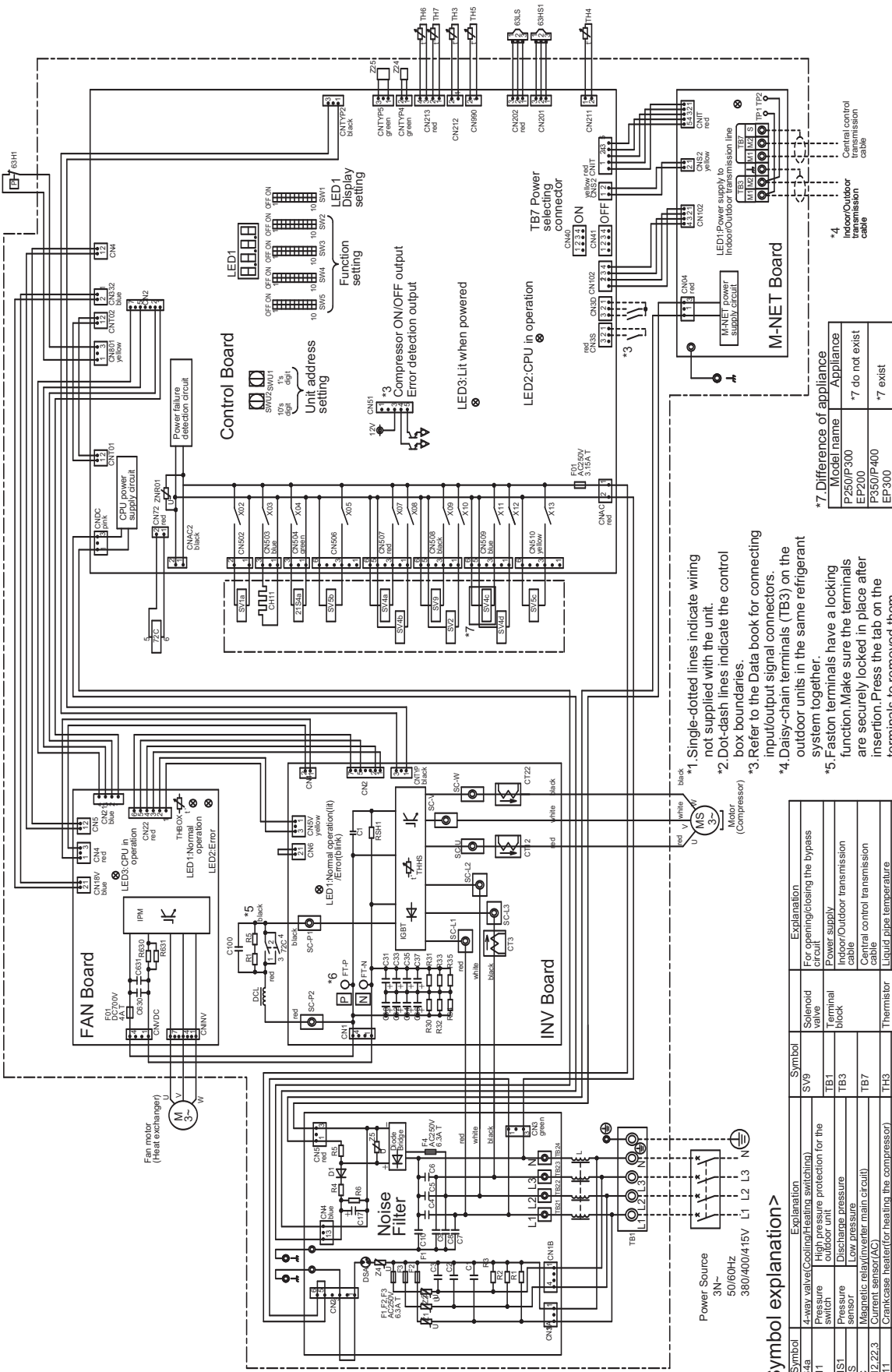

*7 Difference of appliance

Model name	Appliance
P250/P300	*7 do not exist
EP200	
P350/P400	*7 exist
EP-300	

- *1 Single-dotted lines indicate wiring not supplied with the unit.
- *2 Dot-dash lines indicate the control box boundaries.
- *3 Refer to the Data book for connecting input/output signal connectors.
- *4 Daisy-chain terminals (TB3) on the outdoor units in the same refrigerant system together.
- *5 Faston terminals have a locking function. Make sure the terminals are securely locked in place after insertion. Press the tab on the terminals to remove them.
- *6 Control box houses high-voltage parts. Before inspecting the inside of the control box, turn off the power, keep the unit off for at least 10 minutes, and confirm that the voltage between FT-P and FT-N on INV Board has dropped to DC200V or less.

<Symbol explanation>

Symbol	Explanation
SV9	For opening/closing the bypass circuit
SV9	Solenoid valve
TB1	Terminal block
TB3	Indoor/Outdoor transmission cable
TB7	Central control transmission cable
TH3	Thermistor
TH4	Liquid pipe temperature sensor
TH5	ACC inlet pipe temperature sensor
TH6	Heat exchanger inlet pipe temperature sensor
TH7	OA temperature sensor
TH8	Control box internal temperature sensor
THHS	GBT temperature sensor
SV5c	Function setting connector

Measurement condition
PURY-P250,300YHM-A(-BS)

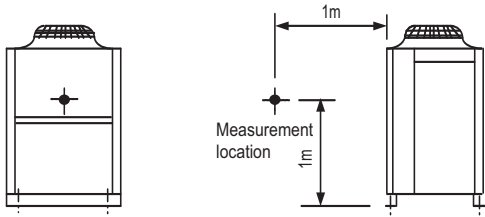

Ref.:PURY_YHM-A_NCC_EUDB_P200-P300_R1

Sound level of PURY-P300YHM-A(-BS)

Ref.:PURY_YHM-A_NCC_EUDB_P300

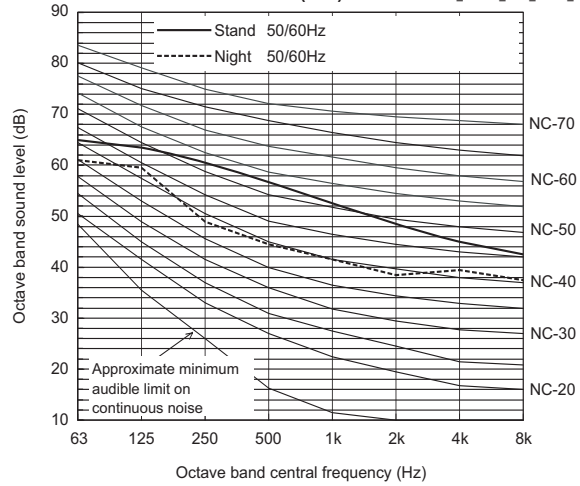

		63	125	250	500	1k	2k	4k	8k	dB(A)
Standard	50/60Hz	65.0	63.5	61.0	56.0	53.0	48.5	45.0	42.5	59.0
Night Mode	50/60Hz	61.0	59.5	49.0	44.5	41.5	38.5	39.5	37.5	50.0

When Night Mode is set, the A/C system's capacity is limited. The system could return to normal operation from Night Mode automatically in the case that the operation condition is severe.

Sound level of PURY-P250YHM-A(-BS)

Ref.:PURY_YHM-A_NCC_EUDB_P250

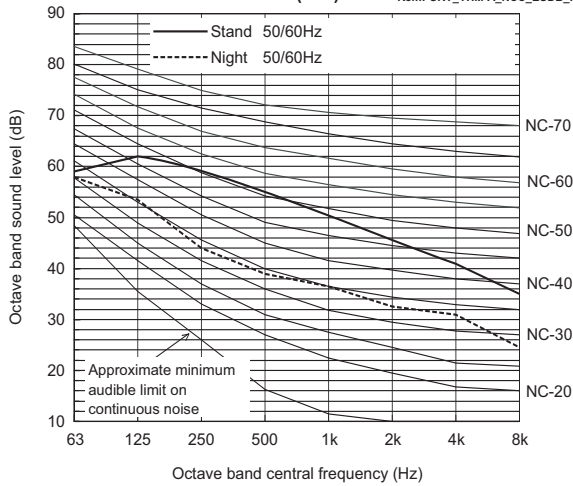

		63	125	250	500	1k	2k	4k	8k	dB(A)
Standard	50/60Hz	59.0	62.0	60.0	54.0	50.5	46.0	41.0	35.0	57.0
Night Mode	50/60Hz	58.0	53.5	44.0	39.0	36.5	32.5	31.0	24.5	44.0

When Night Mode is set, the A/C system's capacity is limited. The system could return to normal operation from Night Mode automatically in the case that the operation condition is severe.

Measurement condition
PURY-P350,400YHM-A(-BS)

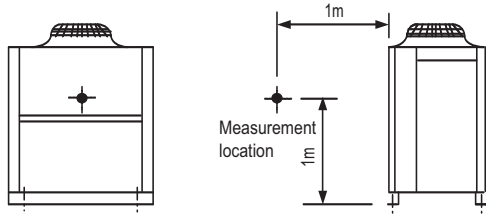

Ref.:PURY_YHM-A_NCC_EUDB_P350-P400_R1

Sound level of PURY-P350YHM-A(-BS)

Ref.:PURY_YHM-A_NCC_EUDB_P350

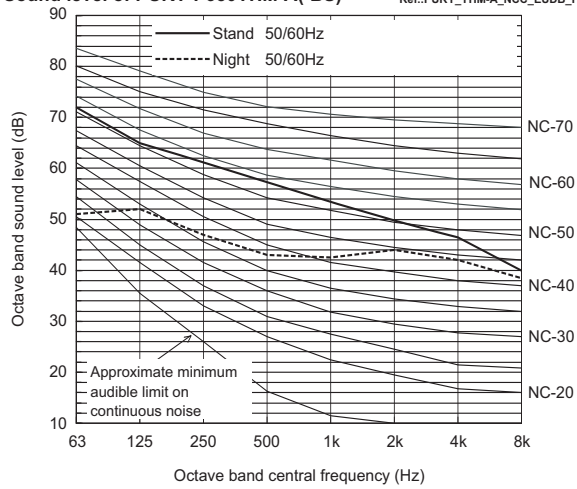

		63	125	250	500	1k	2k	4k	8k	dB(A)
Standard	50/60Hz	72.0	65.0	61.5	57.0	53.5	50.0	46.5	40.0	60.0
Night Mode	50/60Hz	51.0	52.0	47.0	43.0	42.5	44.0	42.0	38.5	50.0

When Night Mode is set, the A/C system's capacity is limited. The system could return to normal operation from Night Mode automatically in the case that the operation condition is severe.

Sound level of PURY-P400YHM-A(-BS)

Ref.:PURY_YHM-A_NCC_EUDB_P400

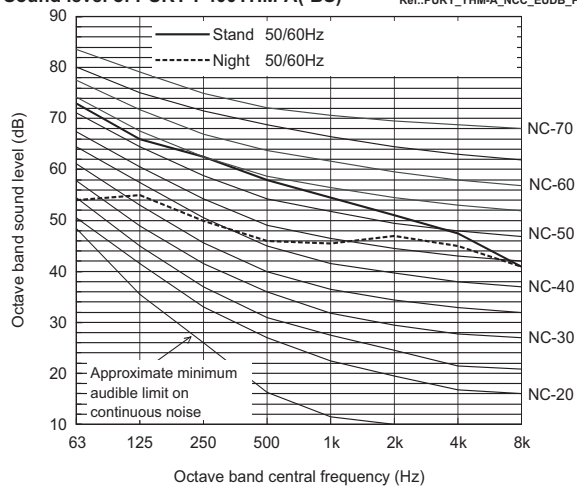

		63	125	250	500	1k	2k	4k	8k	dB(A)
Standard	50/60Hz	73.0	66.0	62.5	58.0	54.5	51.0	47.5	41.0	61.0
Night Mode	50/60Hz	54.0	55.0	50.0	46.0	45.5	47.0	45.0	41.0	53.0

When Night Mode is set, the A/C system's capacity is limited. The system could return to normal operation from Night Mode automatically in the case that the operation condition is severe.

Measurement condition
PURY-P500,550,600YSHM-A(-BS)

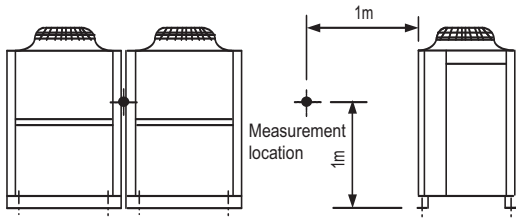

Ref.:PURY_YHM-A_NCC_EUDB_P450-P600_R1

Sound level of PURY-P550YSHM-A(-BS) Ref.:PURY_YHM-A_NCC_EUDB_P550

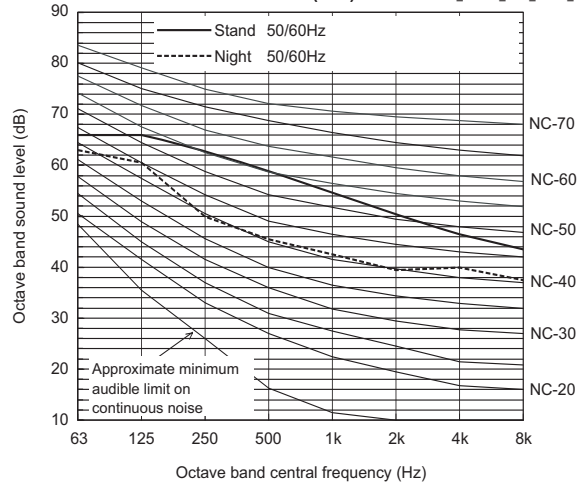

		63	125	250	500	1k	2k	4k	8k	dB(A)
Standard	50/60Hz	66.0	66.0	63.5	58.0	55.0	50.5	46.5	43.5	61.0
Night Mode	50/60Hz	63.0	60.5	50.0	45.5	42.5	39.5	40.0	37.5	51.0

When Night Mode is set, the A/C system's capacity is limited. The system could return to normal operation from Night Mode automatically in the case that the operation condition is severe.

Sound level of PURY-P500YSHM-A(-BS) Ref.:PURY_YHM-A_NCC_EUDB_P500

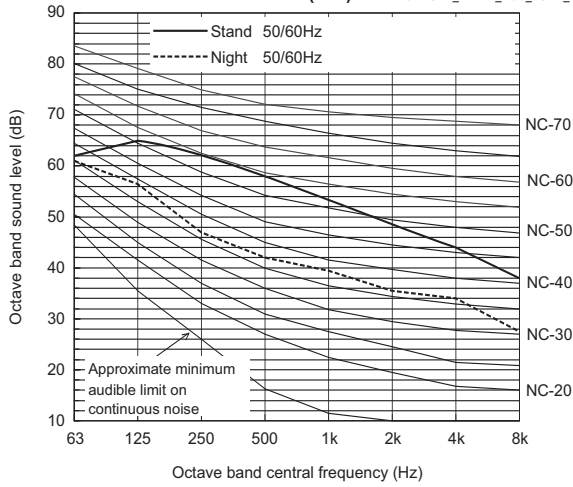

		63	125	250	500	1k	2k	4k	8k	dB(A)
Standard	50/60Hz	62.0	65.0	63.0	57.0	53.5	49.0	44.0	38.0	60.0
Night Mode	50/60Hz	61.0	56.5	47.0	42.0	39.5	35.5	34.0	27.5	47.0

When Night Mode is set, the A/C system's capacity is limited. The system could return to normal operation from Night Mode automatically in the case that the operation condition is severe.

Sound level of PURY-P600YSHM-A(-BS) Ref.:PURY_YHM-A_NCC_EUDB_P600

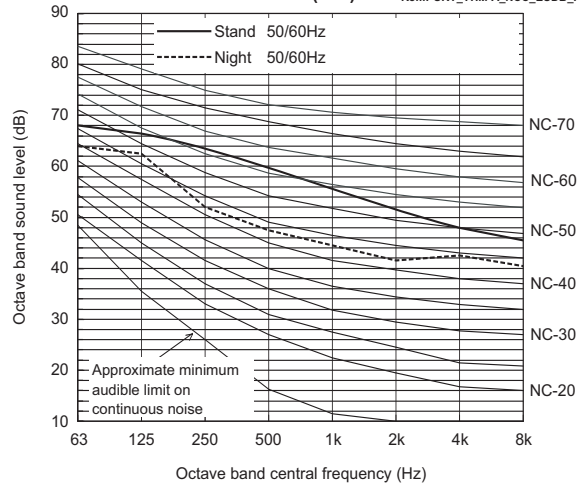

		63	125	250	500	1k	2k	4k	8k	dB(A)
Standard	50/60Hz	68.0	66.5	64.0	59.0	56.0	51.5	48.0	45.5	62.0
Night Mode	50/60Hz	64.0	62.5	52.0	47.5	44.5	41.5	42.5	40.5	53.0

When Night Mode is set, the A/C system's capacity is limited. The system could return to normal operation from Night Mode automatically in the case that the operation condition is severe.

Measurement condition
PURY-P650,700YSHM-A(-BS)

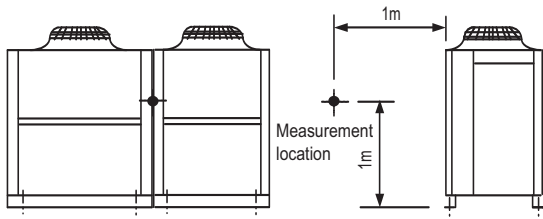

Ref.:PURY_YHM-A_NCC_EUDB_P650-P700_R1

Sound level of PURY-P650YSHM-A(-BS)

Ref.:PURY_YHM-A_NCC_EUDB_P650

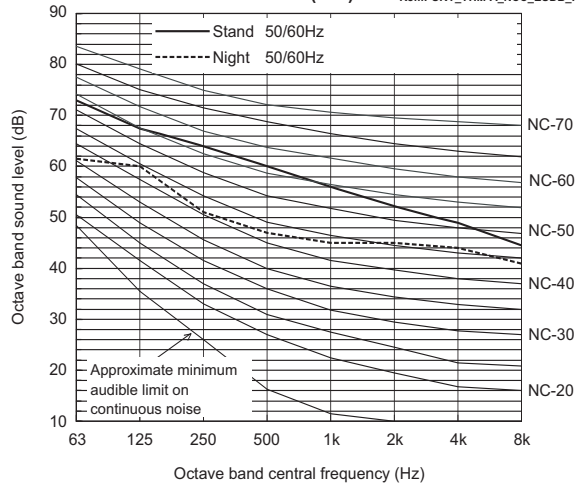

		63	125	250	500	1k	2k	4k	8k	dB(A)
Standard	50/60Hz	73.0	67.5	64.5	59.5	56.0	52.5	49.0	44.5	62.5
Night Mode	50/60Hz	61.5	60.0	51.0	47.0	45.0	45.0	44.0	41.0	53.0

When Night Mode is set, the A/C system's capacity is limited. The system could return to normal operation from Night Mode automatically in the case that the operation condition is severe.

Sound level of PURY-P700YSHM-A(-BS)

Ref.:PURY_YHM-A_NCC_EUDB_P700

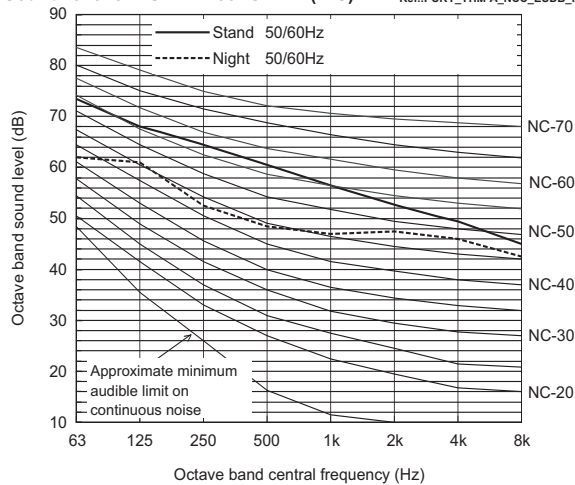

		63	125	250	500	1k	2k	4k	8k	dB(A)
Standard	50/60Hz	73.5	68.0	65.0	60.0	56.5	53.0	49.5	45.0	63.0
Night Mode	50/60Hz	62.0	61.0	52.5	48.5	47.0	47.5	46.0	42.5	54.5

When Night Mode is set, the A/C system's capacity is limited. The system could return to normal operation from Night Mode automatically in the case that the operation condition is severe.

Measurement condition
PURY-P750,800YSHM-A(-BS)

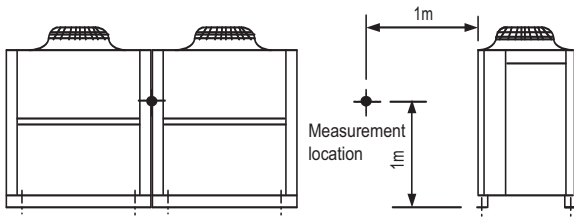

Ref.:PURY_YHM-A_NCC_EUDB_P750-P800_R1

Sound level of PURY-P750YSHM-A(-BS)

Ref.:PURY_YHM-A_NCC_EUDB_P750

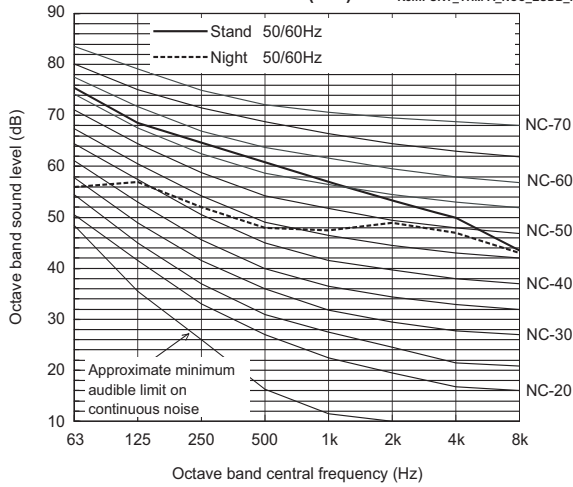

		63	125	250	500	1k	2k	4k	8k	dB(A)
Standard	50/60Hz	75.5	68.5	65.0	60.5	57.0	53.5	50.0	43.5	63.5
Night Mode	50/60Hz	56.0	57.0	52.0	48.0	47.5	49.0	47.0	43.0	55.0

When Night Mode is set, the A/C system's capacity is limited. The system could return to normal operation from Night Mode automatically in the case that the operation condition is severe.

Sound level of PURY-P800YSHM-A(-BS)

Ref.:PURY_YHM-A_NCC_EUDB_P800

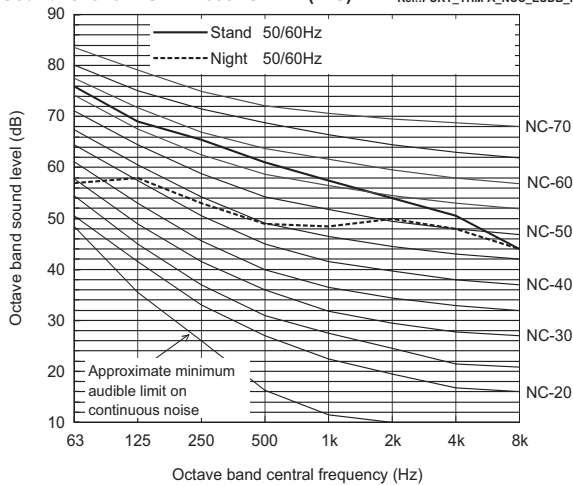

		63	125	250	500	1k	2k	4k	8k	dB(A)
Standard	50/60Hz	76.0	69.0	65.5	61.0	57.5	54.0	50.5	44.0	64.0
Night Mode	50/60Hz	57.0	58.0	53.0	49.0	48.5	50.0	48.0	44.0	56.0

When Night Mode is set, the A/C system's capacity is limited. The system could return to normal operation from Night Mode automatically in the case that the operation condition is severe.

6-1. Correction by temperature

CITY MULTI™ could have varied capacity at different designing temperature. Using the nominal cooling/heating capacity value and the ratio below, the capacity can be observed at various temperature.

PURY-		P250YHM-A(-BS)
Nominal Cooling Capacity	kW	28.0
	BTU/h	95,500
Input	kW	7.73

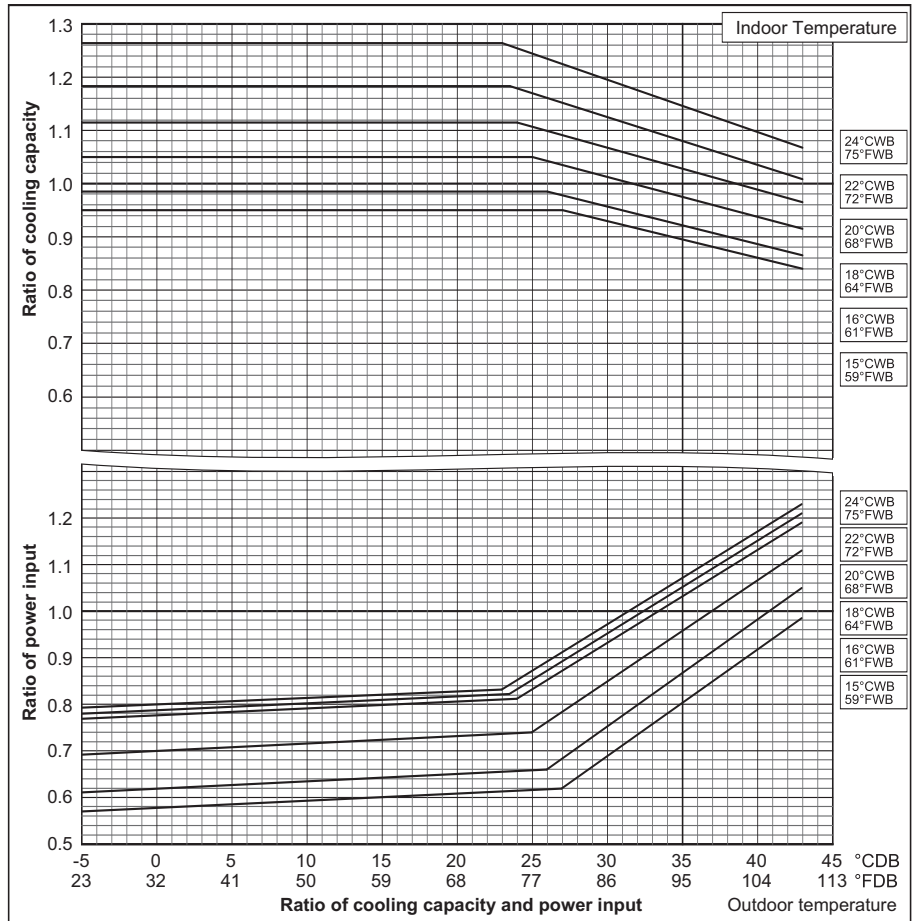

PURY-		P250YHM-A(-BS)
Nominal Heating Capacity	kW	31.5
	BTU/h	107,500
Input	kW	7.83

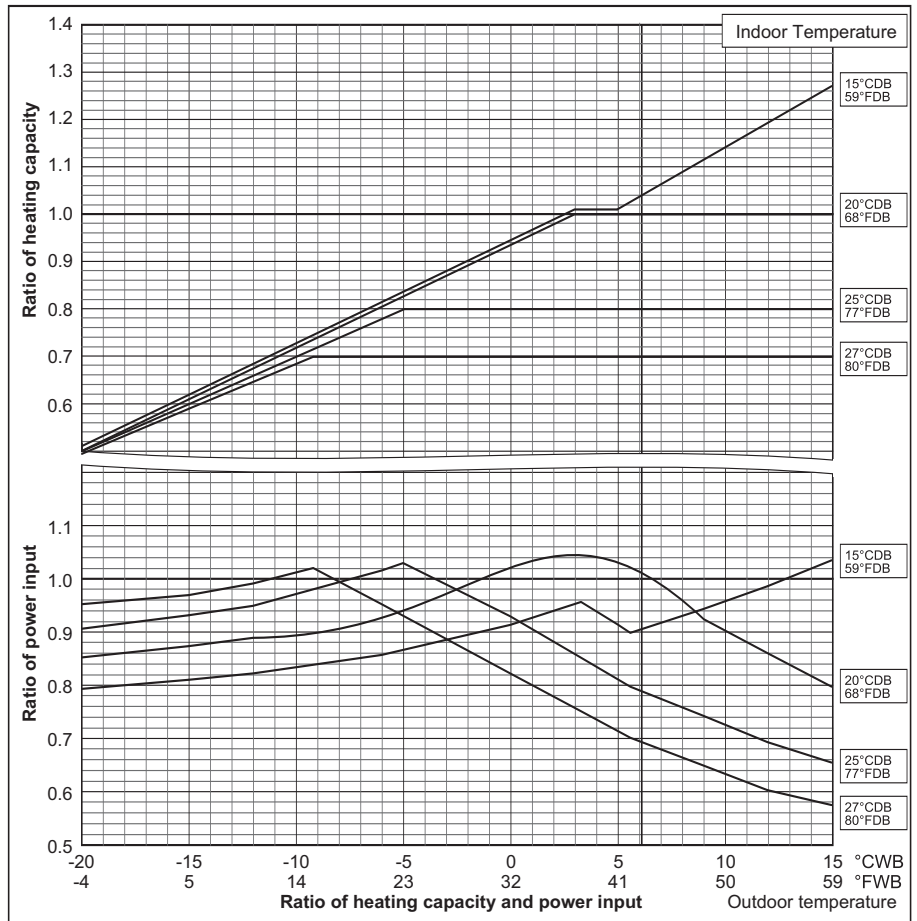

Ref:PURY_YHM-A_CbTMP_EUDB_P200-P250

PURY-		P300YHM-A(-BS)	P350YHM-A(-BS)
Nominal Cooling Capacity	kW	33.5	40.0
	BTU/h	114,300	136,500
Input	kW	9.25	12.47

PURY-		P400YHM-A(-BS)
Nominal Cooling Capacity	kW	45.0
	BTU/h	153,500
Input	kW	13.74

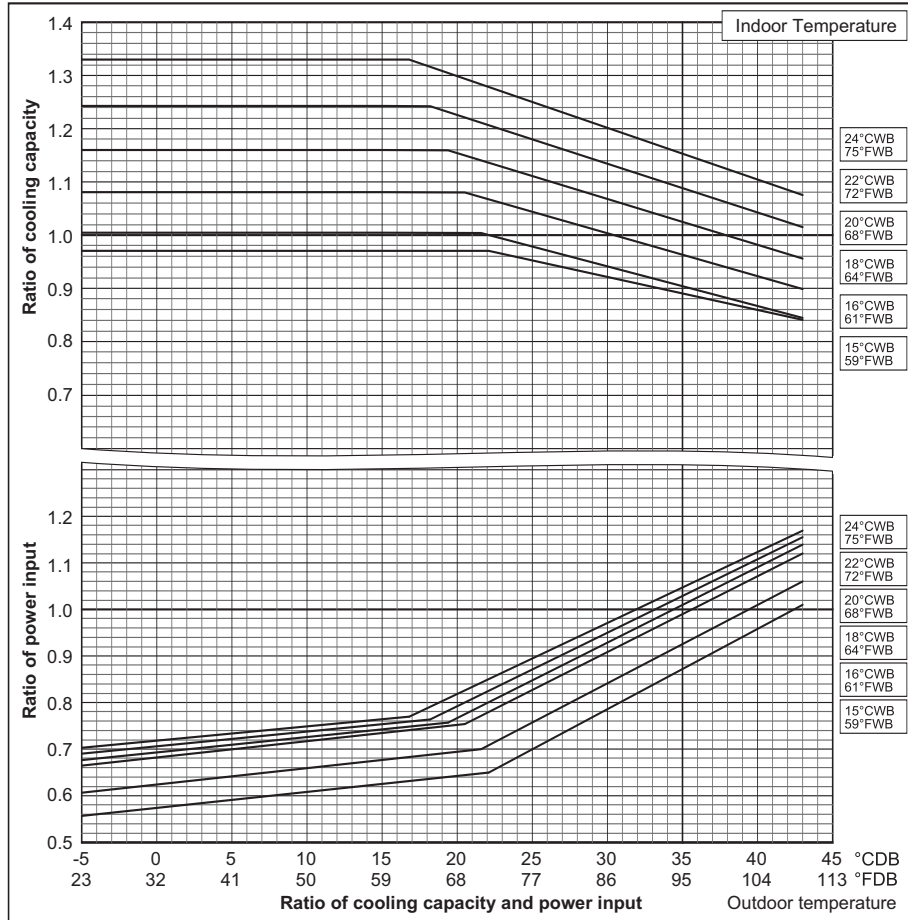

PURY-		P300YHM-A(-BS)	P350YHM-A(-BS)
Nominal Heating Capacity	kW	37.5	45.0
	BTU/h	128,000	153,500
Input	kW	9.58	12.47

PURY-		P400YHM-A(-BS)
Nominal Heating Capacity	kW	50.0
	BTU/h	170,600
Input	kW	13.71

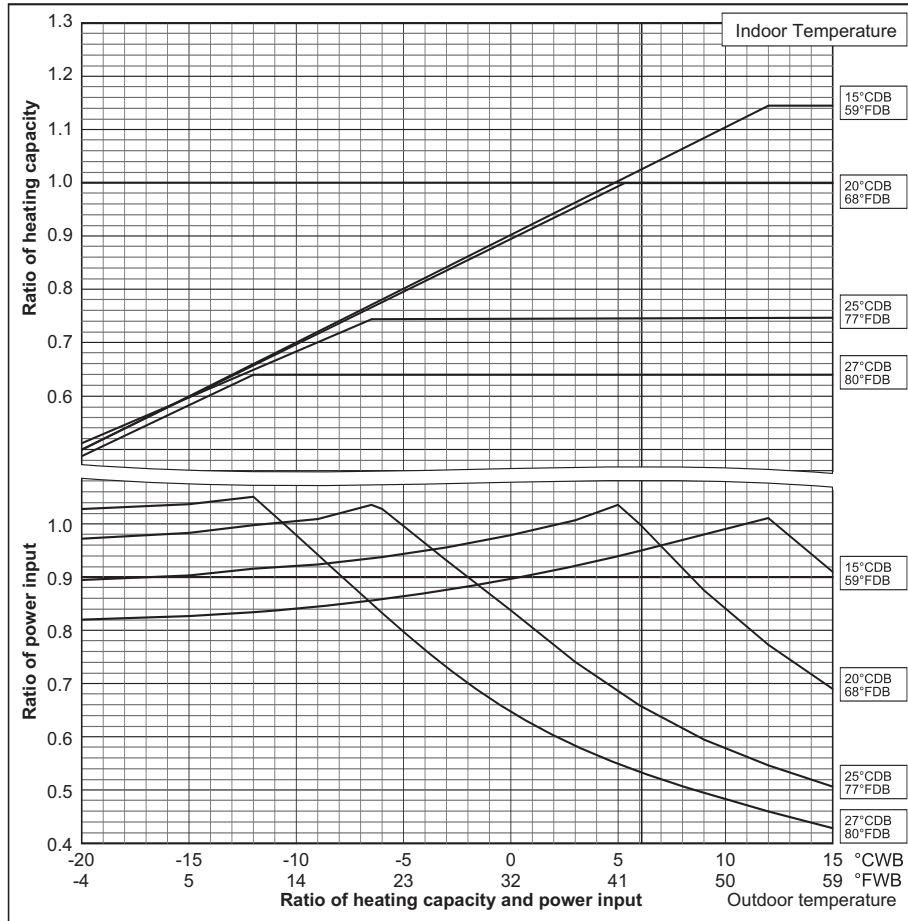

Ref:PURY_YHM-A_CbTMP_EUDB_P300-P400

PURY-		P500YSHM-A(-BS)
Nominal Cooling Capacity	kW	56.0
	BTU/h	191,100
Input	kW	16.75

PURY-		P550YSHM-A(-BS)	P600YSHM-A(-BS)
Nominal Cooling Capacity	kW	63.0	69.0
	BTU/h	215,000	235,400
Input	kW	18.68	19.64

PURY-		P650YSHM-A(-BS)
Nominal Cooling Capacity	kW	73.0
	BTU/h	249,100
Input	kW	22.80

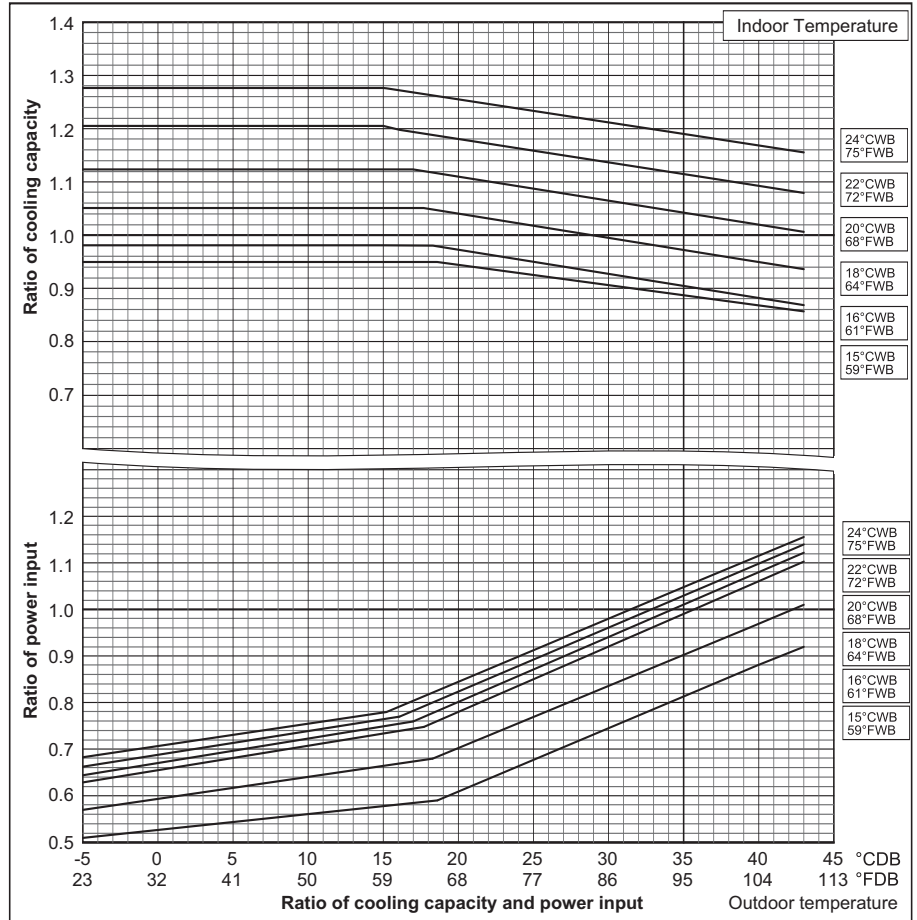

PURY-		P500YSHM-A(-BS)
Nominal Heating Capacity	kW	63.0
	BTU/h	215,000
Input	kW	16.79

PURY-		P550YSHM-A(-BS)	P600YSHM-A(-BS)
Nominal Heating Capacity	kW	69.0	76.5
	BTU/h	235,400	261,000
Input	kW	18.81	20.83

PURY-		P650YSHM-A(-BS)
Nominal Heating Capacity	kW	81.5
	BTU/h	278,100
Input	kW	22.55

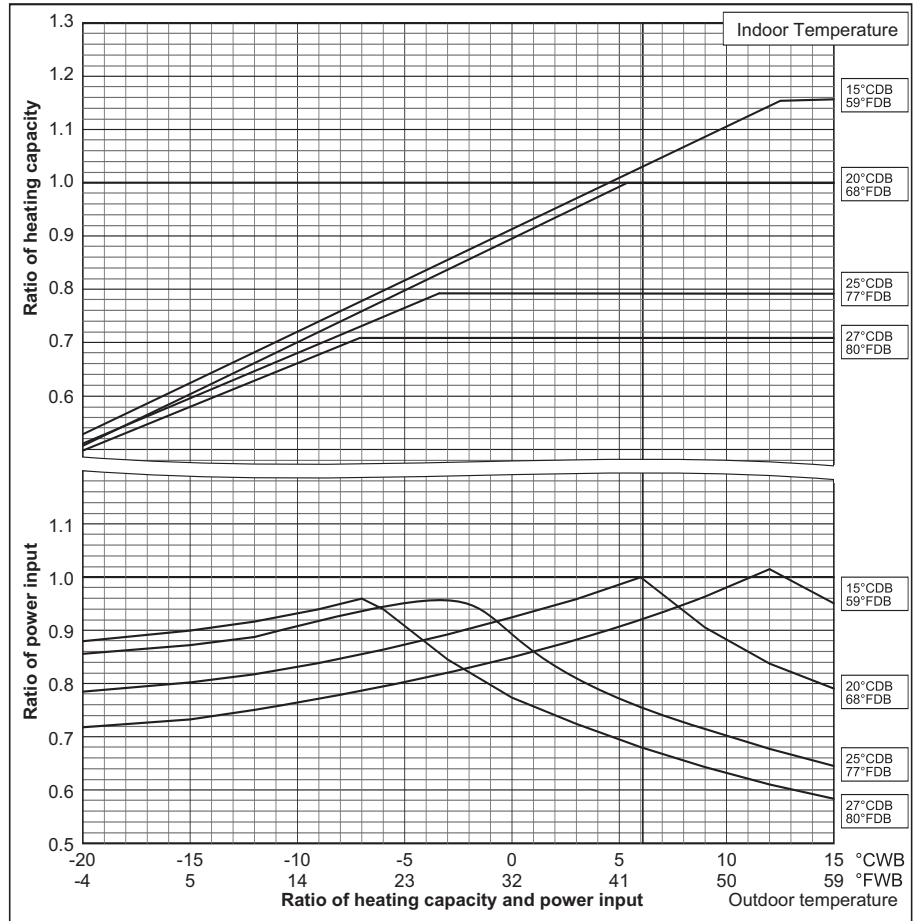

Ref:PURY_YHM-A_CbTMP_EUDB_P450-P650

PURY-		P700YSHM-A(-BS)	P750YSHM-A(-BS)
Nominal Cooling Capacity	kW	80.0	85.0
	BTU/h	273,000	290,000
Input	kW	24.72	27.86

PURY-		P800YSHM-A(-BS)
Nominal Cooling Capacity	kW	90.0
	BTU/h	307,100
Input	kW	29.75

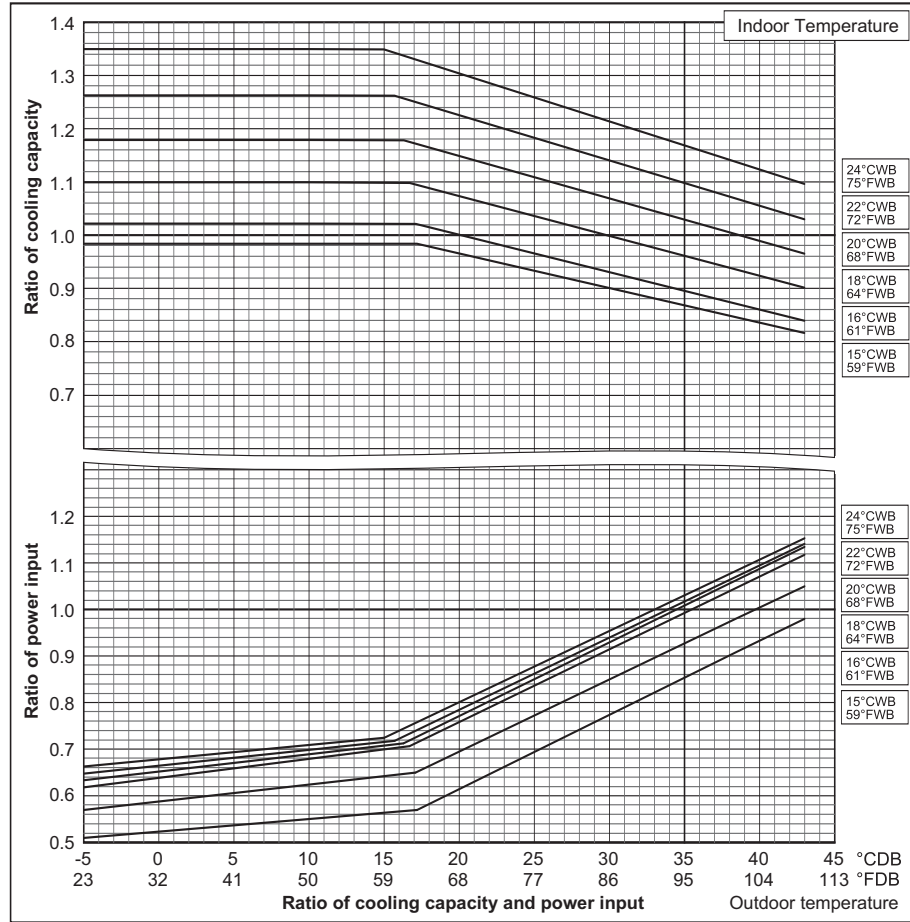

PURY-		P700YSHM-A(-BS)	P750YSHM-A(-BS)
Nominal Heating Capacity	kW	88.0	95.0
	BTU/h	300,300	324,100
Input	kW	24.30	26.36

PURY-		P800YSHM-A(-BS)
Nominal Heating Capacity	kW	100.0
	BTU/h	341,200
Input	kW	27.64

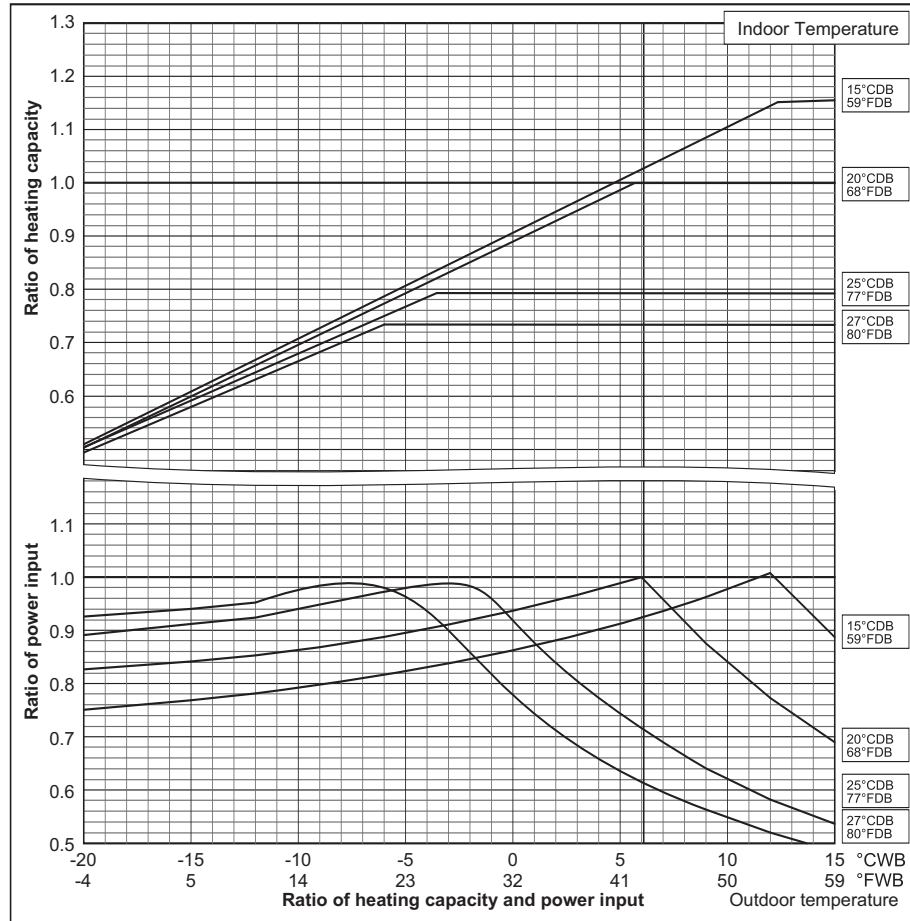

Ref:PURY_YHM-A_CbTMP_EUDB_P700-P800

6-2. Correction by total indoor

CITY MULTI™ system has different capacity and input at different total capacity of indoor unit connected. Using following tables, the maximum capacity can be observed so as to ensure the system having enough capacity to meet the conditions.

PURY-P250YHM-A(-BS)

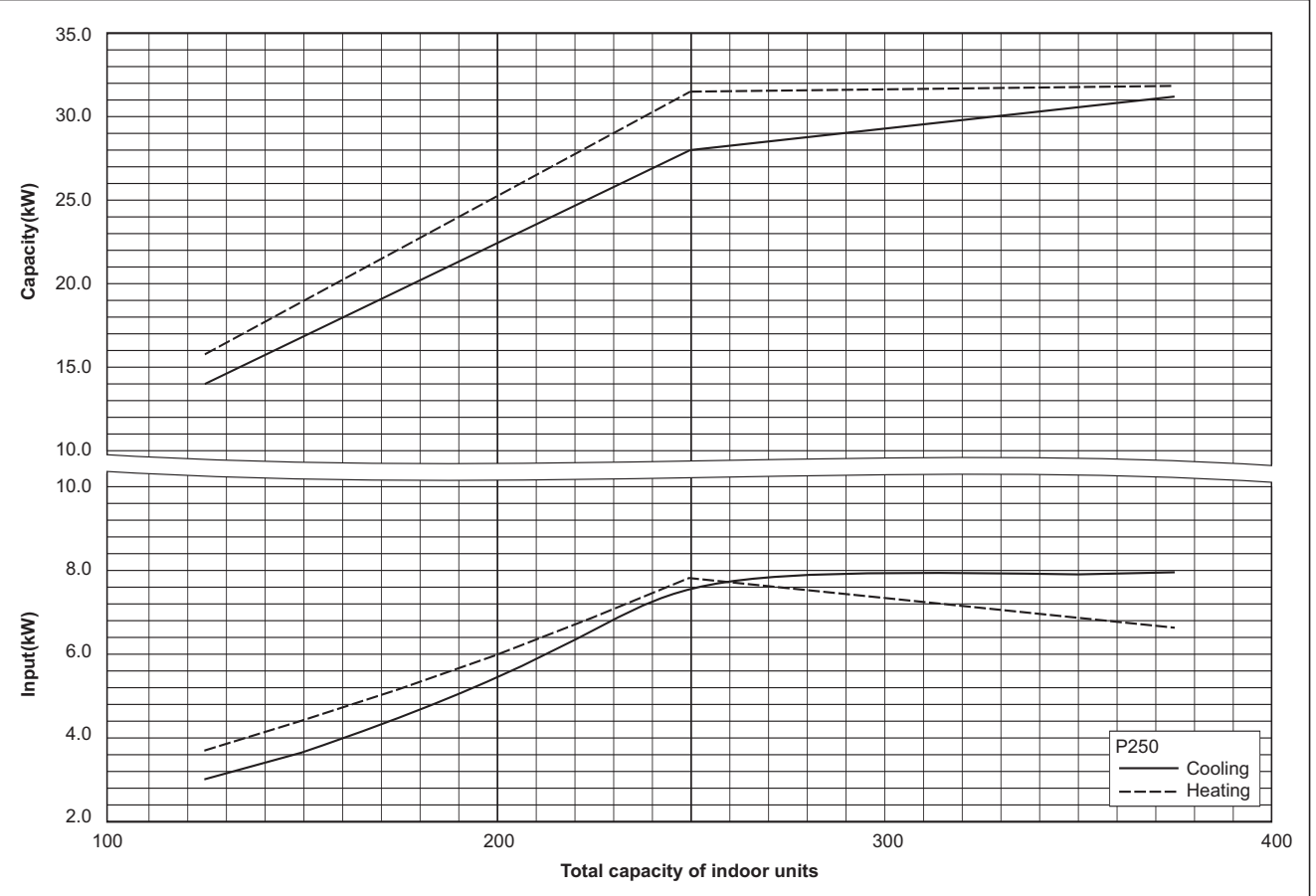

PURY-P300,350YHM-A(-BS)

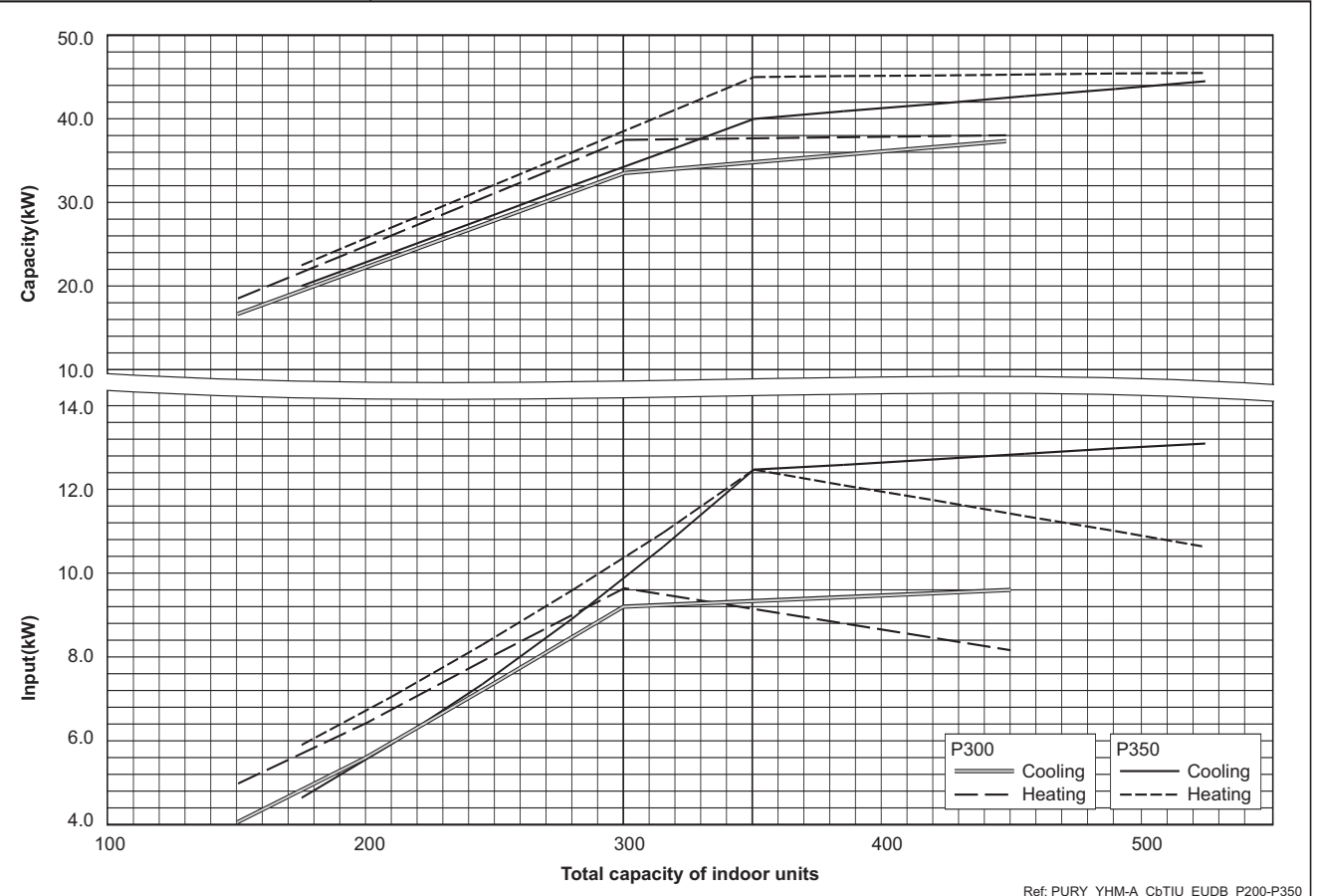

Ref: PURY_YHM-A_CbTIU_EUDB_P200-P350

PURY-P400Y(S)HM-A(-BS)

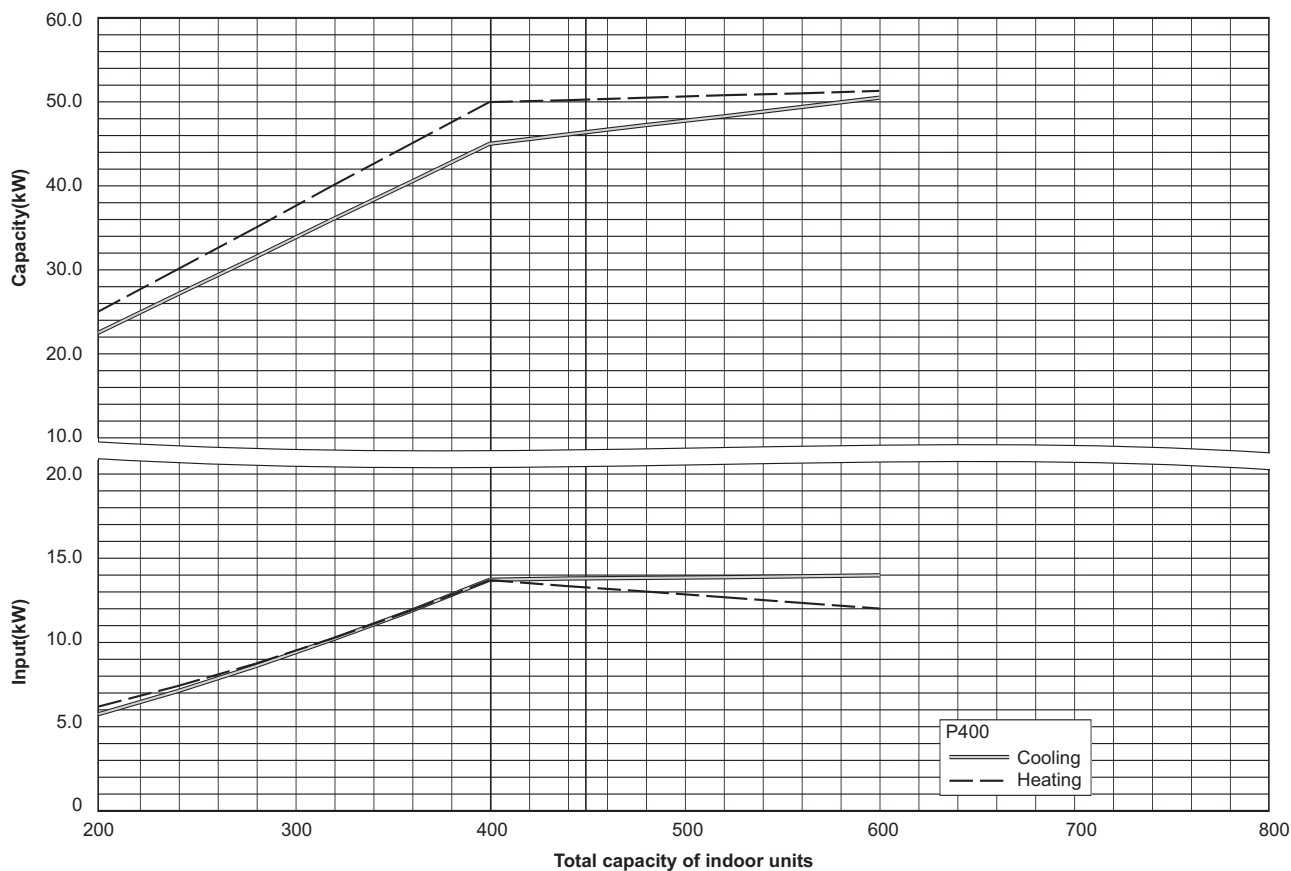

PURY-P500,550YSHM-A(-BS)

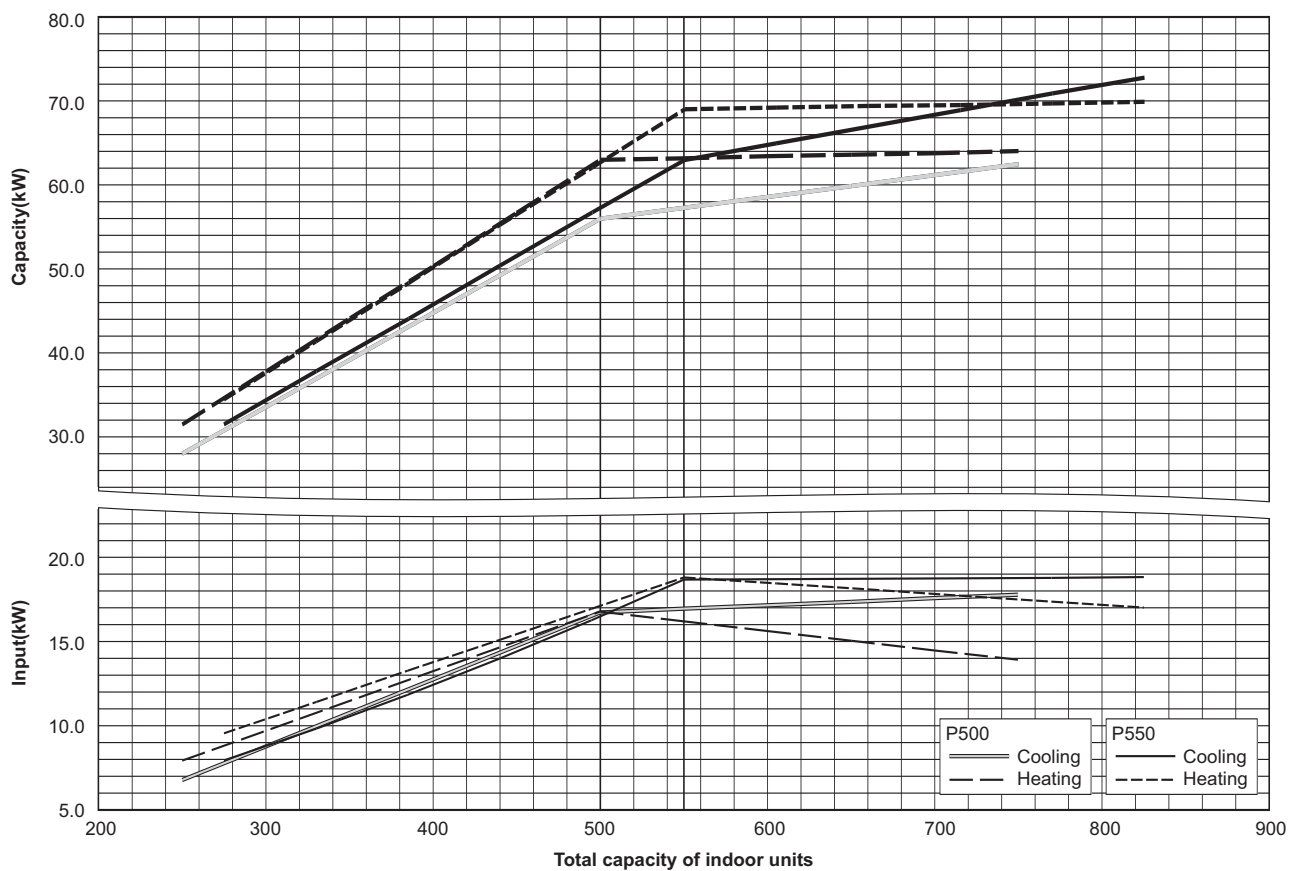

Ref: PURY_YHM-A_CbTIU_EUDB_P400-P550

PURY-P600,650YSHM-A(-BS)

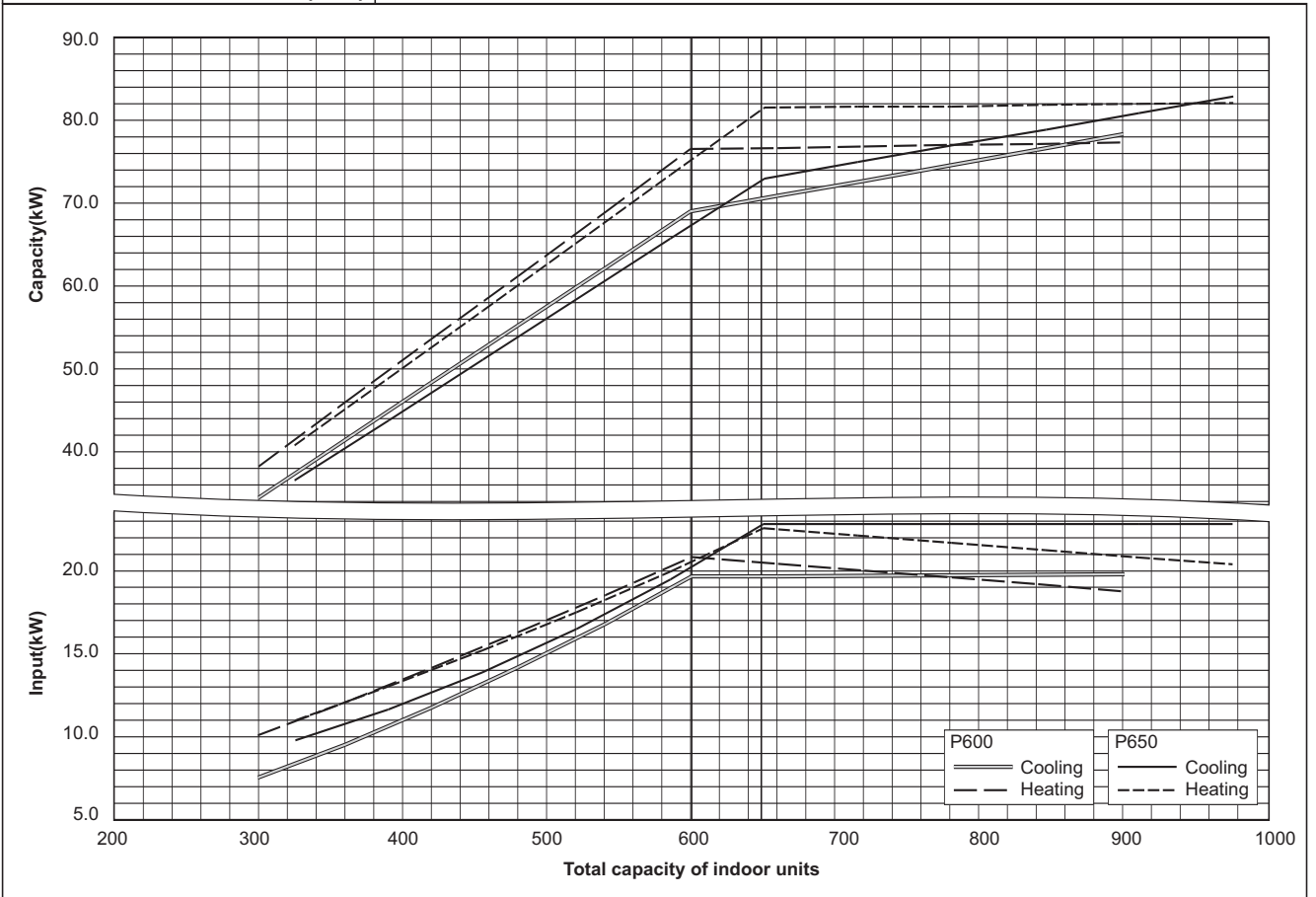

PURY-P700,750YSHM-A(-BS)

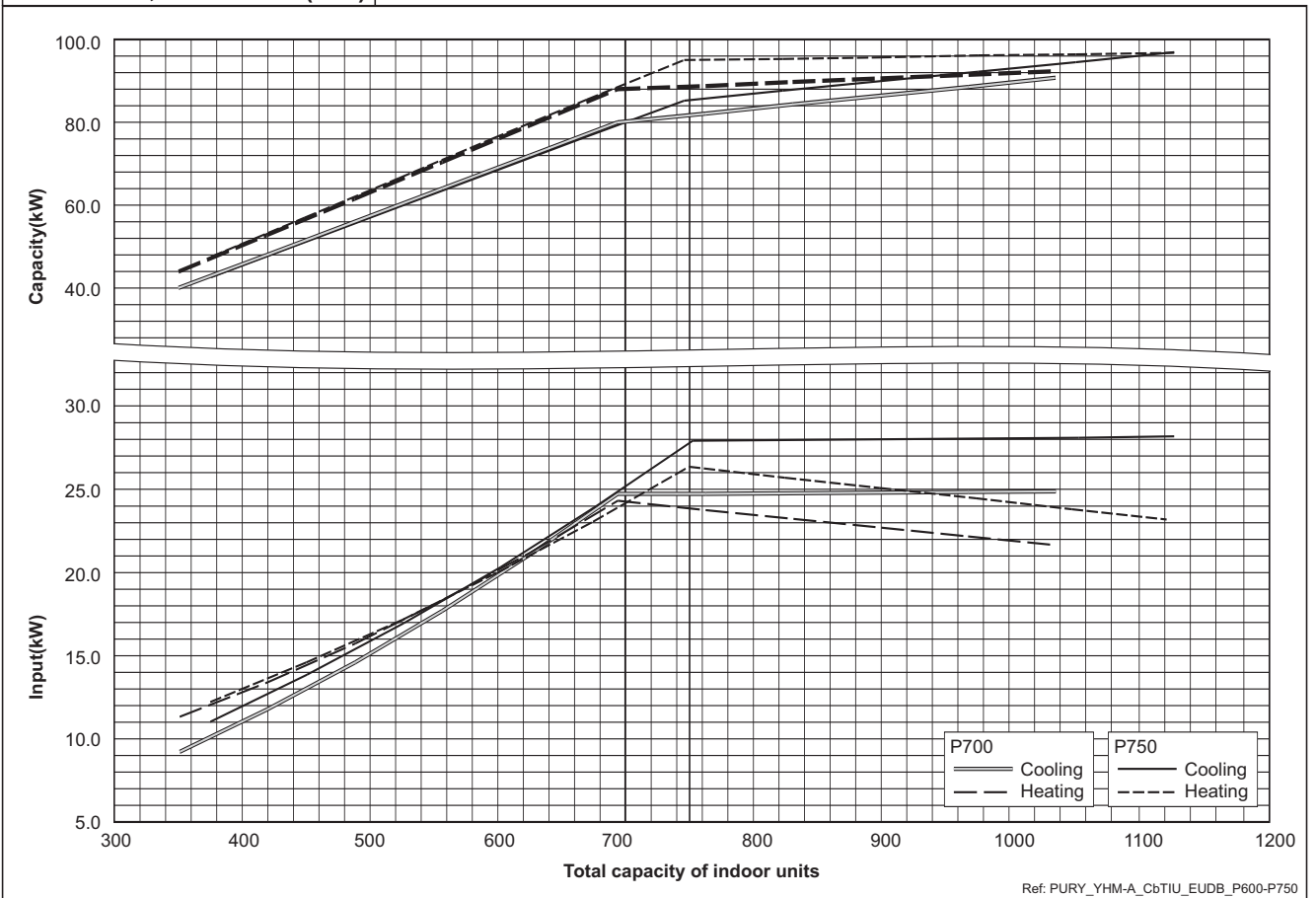

Ref: PURY_YHM-A_CbTIU_EUDB_P600-P750

PURY-P800YSHM-A(-BS)

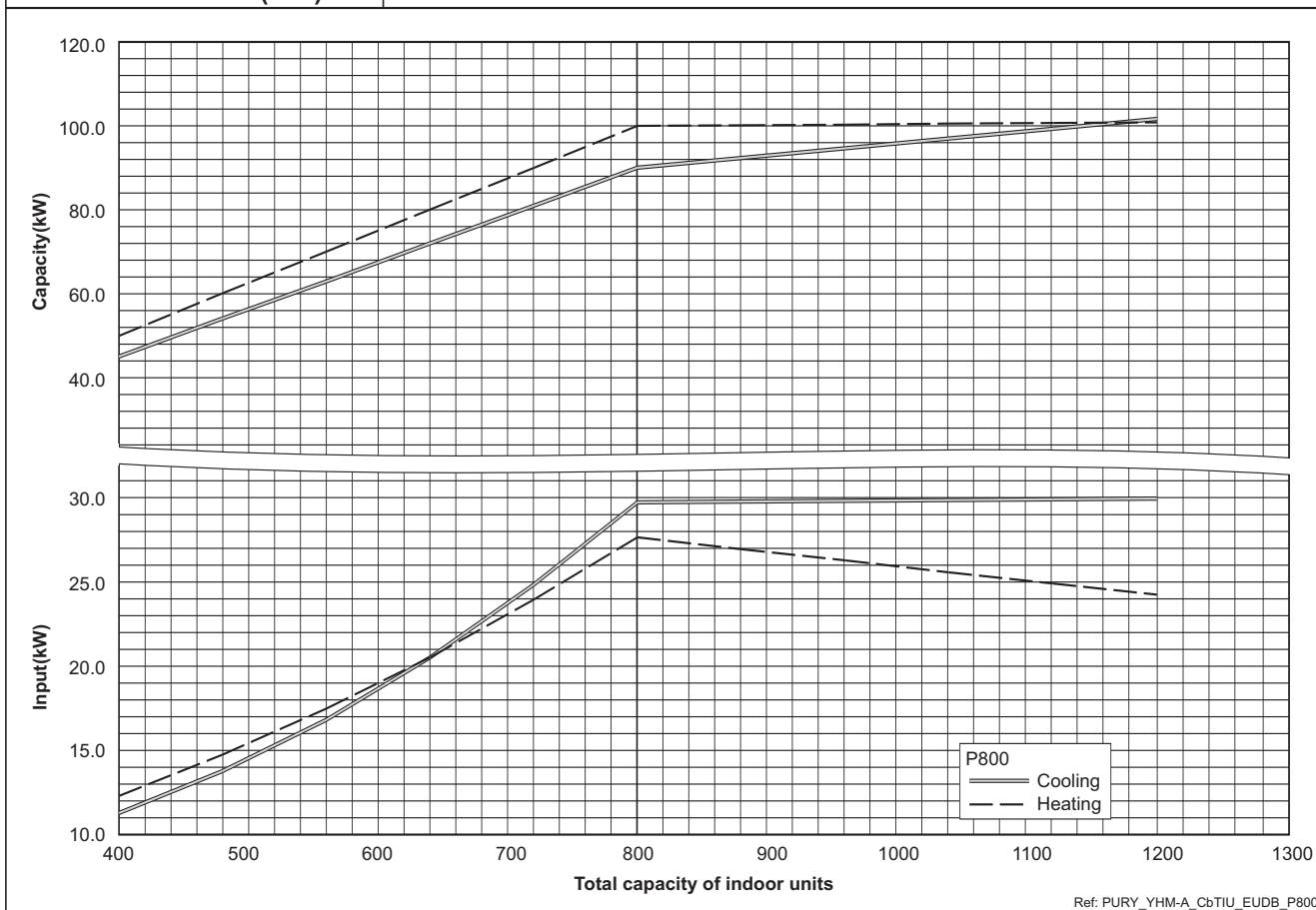

6-3. Correction by refrigerant piping length

CITY MULTI™ system can extend the piping flexibly within its limitation for the actual situation. Yet, a decrease of cooling/heating capacity could happen correspondently. Using following correction factor according to the equivalent length of the piping shown at 6-3-1 and 6-3-2, the capacity can be observed. 6-3-3 shows how to obtain the equivalent length of piping.

6-3-1. Cooling capacity correction

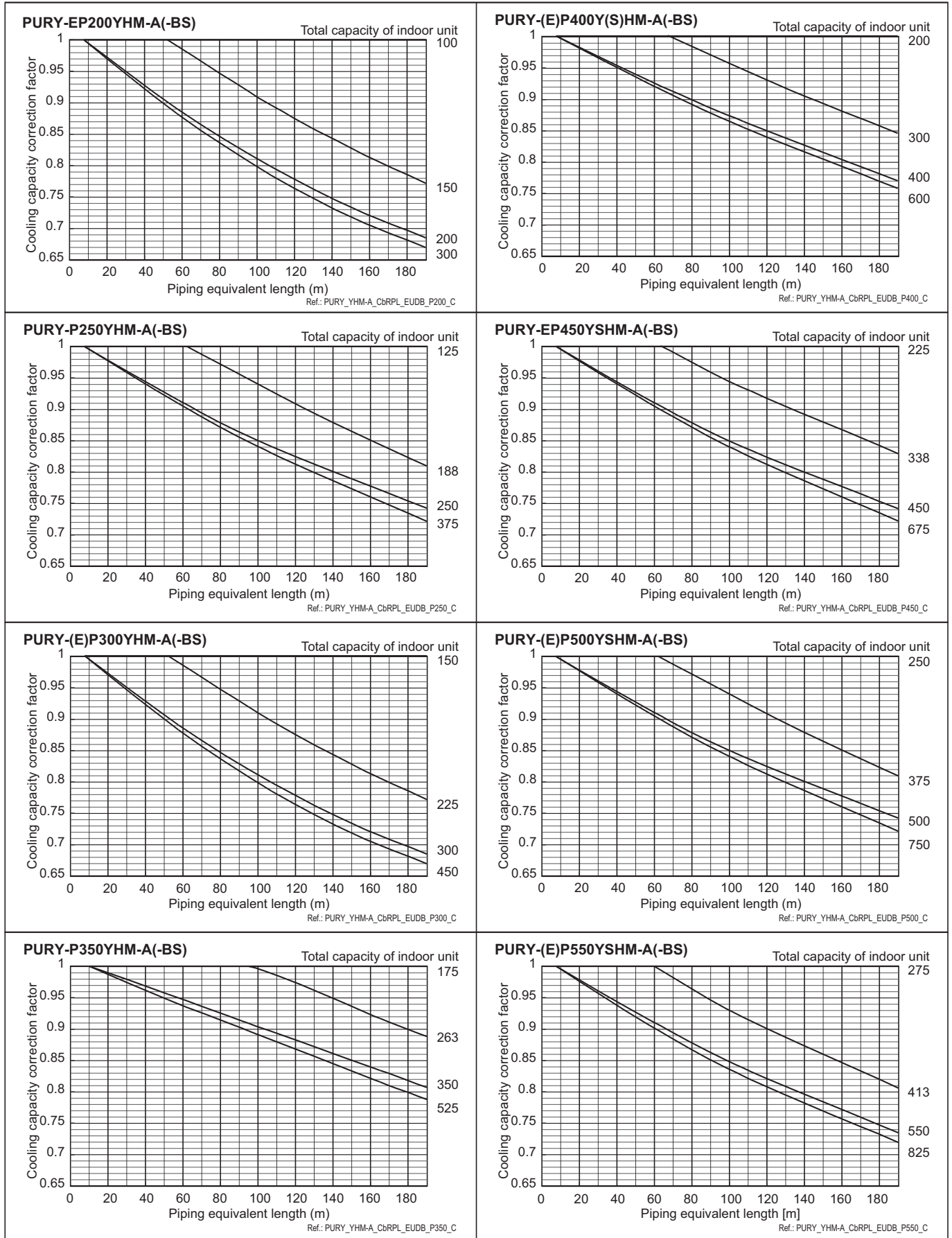

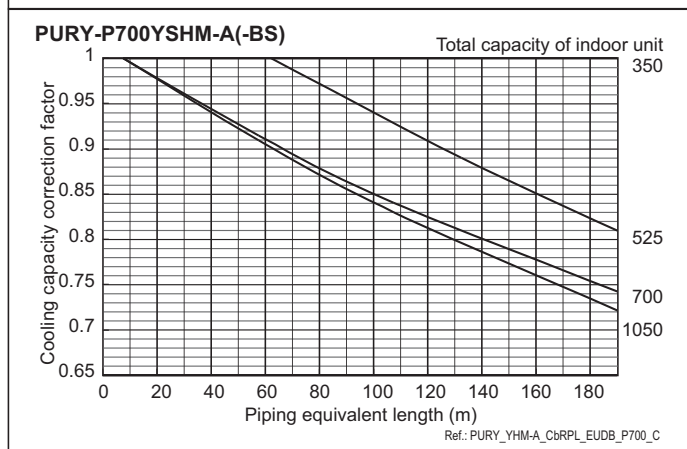
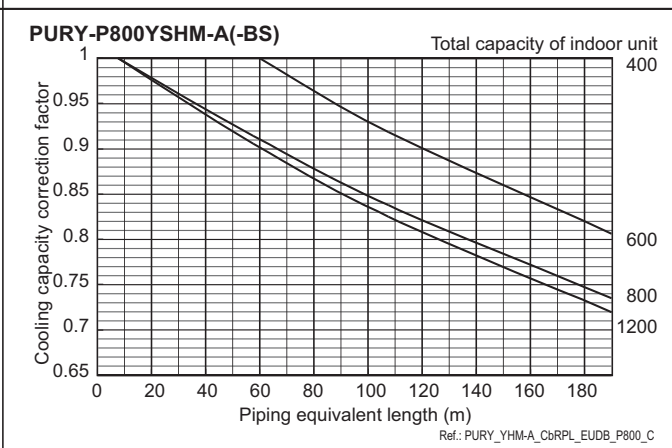
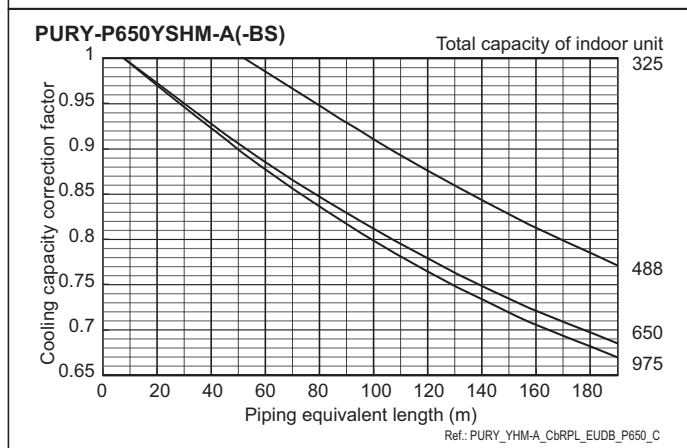
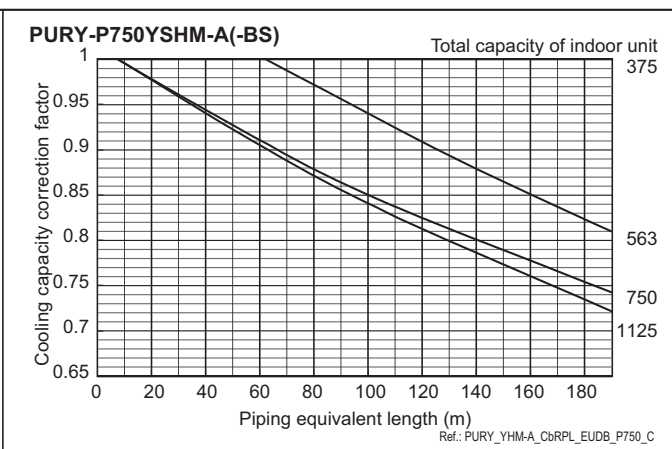
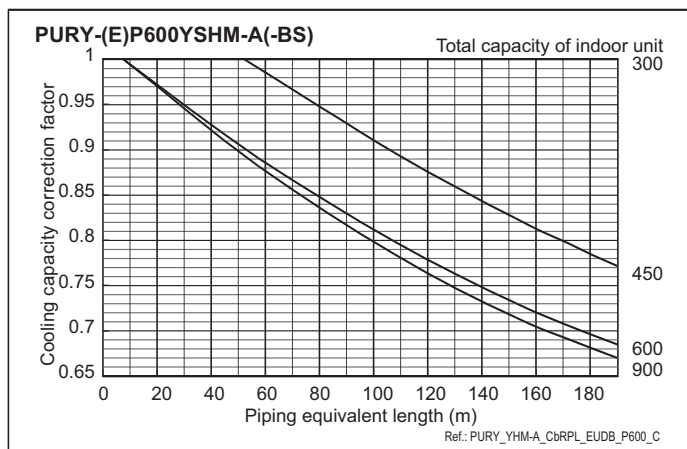

6-3-2. Heating capacity correction

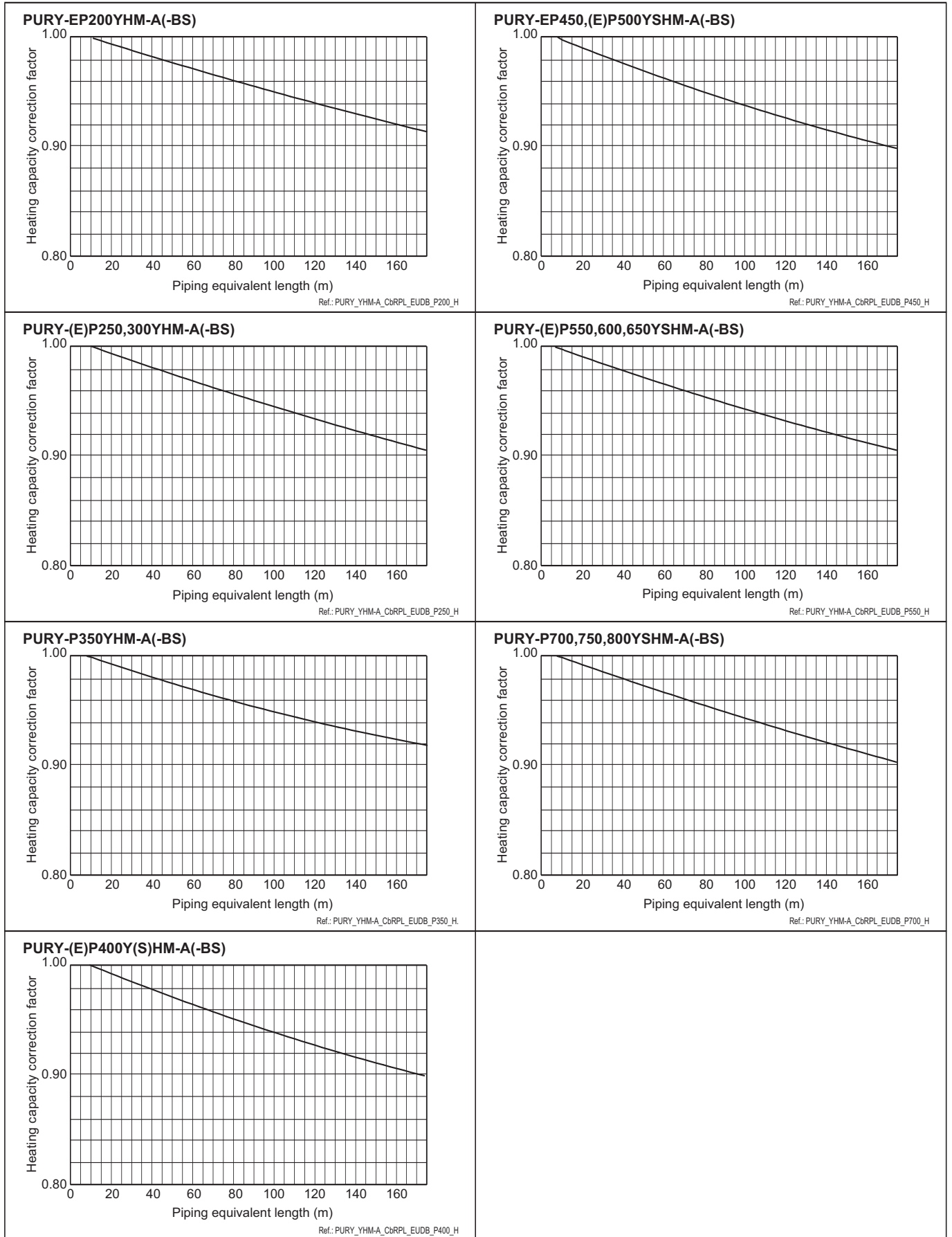

6-3-3. How to obtain the equivalent length of piping**1 PURY-EP200YHM-A(-BS)**

Equivalent length = (Actual piping length to the farthest indoor unit) + (0.35 x number of bent on the piping) m

2 PURY-(E)P250,300YHM-A(-BS)

Equivalent length = (Actual piping length to the farthest indoor unit) + (0.42 x number of bent on the piping) m

3 PURY-P350YHM-A(-BS)

Equivalent length = (Actual piping length to the farthest indoor unit) + (0.47 x number of bent on the piping) m

4 PURY-(E)P400,450,500,550,600,650Y(S)HM-A(-BS)

Equivalent length = (Actual piping length to the farthest indoor unit) + (0.50 x number of bent on the piping) m

5 PURY-P700,750,800YSHM-A(-BS)

Equivalent length = (Actual piping length to the farthest indoor unit) + (0.70 x number of bent on the piping) m

Ref: PURY_YHM-A_EqPLTH_EUDB_ALL

6-4. Correction by port counts of the BC controller

Indoor unit sizes P200 and P250 must be connected to 2 ports on the BC controller.

6-5. Correction at frosting and defrosting

Due to frosting at the outdoor heat exchanger and the automatic defrosting operation, the heating capacity of the outdoor unit should be considered by multiplying the correction factor shown in the table below.

Table of correction factor at frosting and defrosting

Outdoor inlet air temp. °C	6	4	2	1	0	-2	-4	-6	-8	-10	-20
Outdoor inlet air temp. °F	43	39	36	34	32	28	25	21	18	14	-4
PURY-EP200YHM-A(-BS)	1.00	0.95	0.84	0.83	0.83	0.87	0.90	0.95	0.95	0.95	0.95
PURY-P250YHM-A(-BS)	1.00	0.95	0.84	0.83	0.83	0.87	0.90	0.95	0.95	0.95	0.95
PURY-(E)P300YHM-A(-BS)	1.00	0.93	0.82	0.80	0.82	0.86	0.90	0.90	0.95	0.95	0.95
PURY-P350YHM-A(-BS)	1.00	0.93	0.85	0.83	0.84	0.86	0.90	0.90	0.95	0.95	0.95
PURY-(E)P400Y(S)HM-A(-BS)	1.00	0.95	0.90	0.87	0.88	0.89	0.90	0.95	0.95	0.95	0.95
PURY-EP450YSHM-A(-BS)	1.00	0.98	0.89	0.87	0.89	0.90	0.92	0.95	0.95	0.95	0.95
PURY-(E)P500YSHM-A(-BS)	1.00	0.98	0.89	0.86	0.89	0.90	0.92	0.95	0.95	0.95	0.95
PURY-(E)P550YSHM-A(-BS)	1.00	0.94	0.87	0.86	0.87	0.88	0.90	0.90	0.93	0.93	0.93
PURY-(E)P600YSHM-A(-BS)	1.00	0.94	0.84	0.86	0.87	0.88	0.90	0.90	0.93	0.93	0.93
PURY-P650YSHM-A(-BS)	1.00	0.94	0.84	0.86	0.87	0.88	0.90	0.90	0.93	0.93	0.93
PURY-P700YSHM-A(-BS)	1.00	0.98	0.89	0.88	0.89	0.90	0.92	0.95	0.95	0.95	0.95
PURY-P750YSHM-A(-BS)	1.00	0.98	0.89	0.88	0.89	0.90	0.92	0.95	0.95	0.95	0.95
PURY-P800YSHM-A(-BS)	1.00	0.98	0.89	0.88	0.89	0.90	0.92	0.95	0.95	0.95	0.95

Ref.: PURY_YHM-A_CbFROST_EUDB_ALL

6-6. Temp. range of running

• Cooling

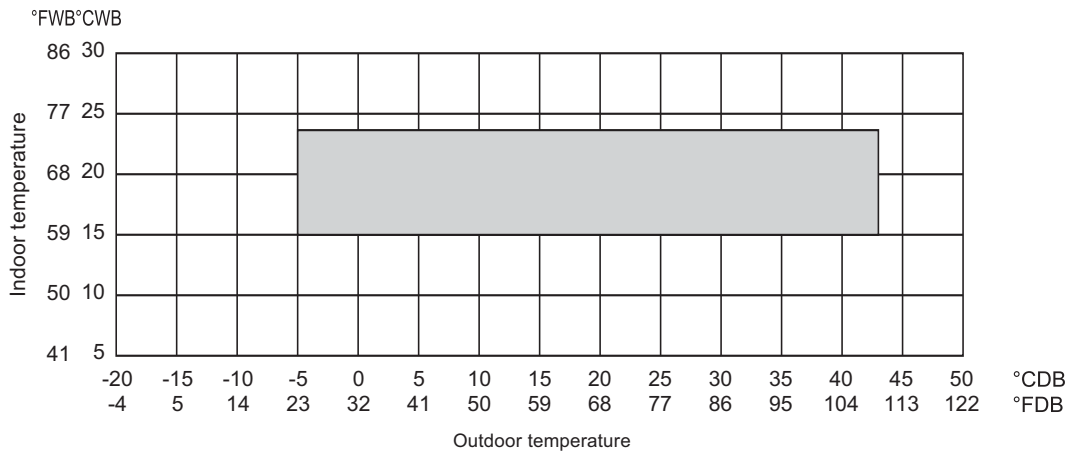

• Heating

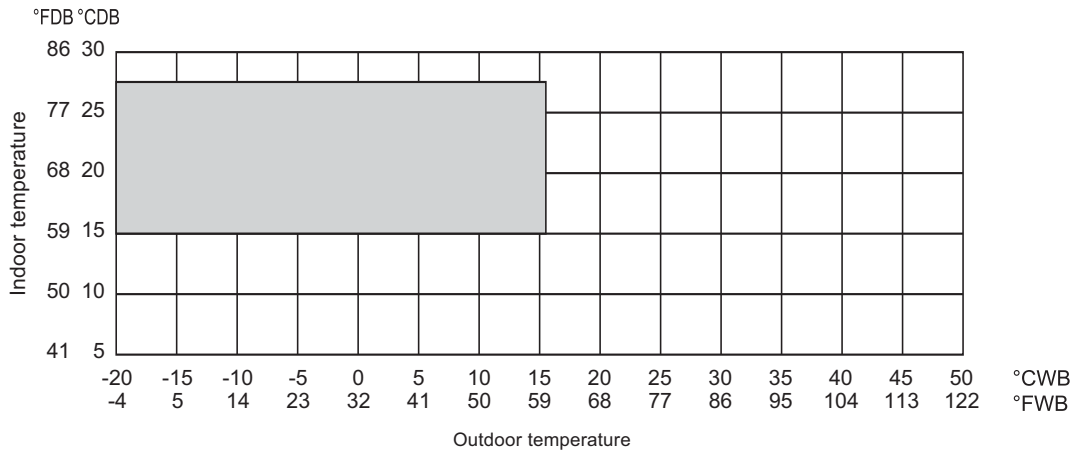

• Combination of cooling/heating operation (Cooling main or Heating main)

Outdoor temperature	Indoor temperature	
	Cooling	Heating
-5 to 21°CDB (23 to 70°FDB)	—	15 to 27°CDB (59 to 81°FDB)
-6 to 15.5°CWB (21 to 60°FWB)	15 to 24°CWB (59 to 75°FWB)	—

Ref.: PURY_YHM-A_TMPRNG_EUDB_ALL

7-1. JOINT

Piping for CITY MULTI™ can be easily done with Joints and headers provided by MITSUBISHI ELECTRIC CORP..

There are 3 sets of Joints selectable for piping. Details for applying the Joint sets are referable to System Design 3, or their own Installation Manual.

CMY-Y102S-G2

Ref.: CMY_Y102S_G2_EXD_EUDB_SI mm

For Gas pipe:

For Liquid pipe:

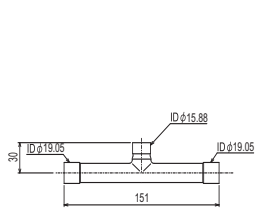

<Deformed pipe(Accessory)>

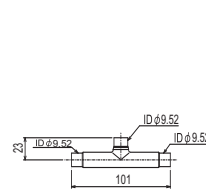
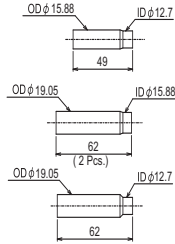

<Deformed pipe(Accessory)>

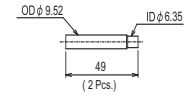

ID: Inner Diameter OD: Outer Diameter

CMY-Y102L-G2

Ref.: CMY_Y102L_G2_EXD_EUDB_SI mm

For Gas pipe:

For Liquid pipe:

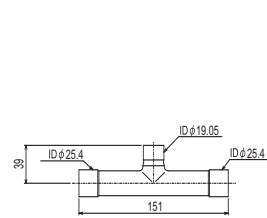

<Deformed pipe(Accessory)>

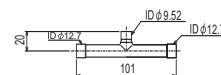
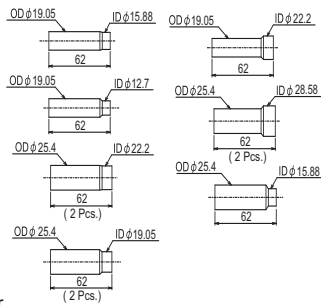

<Deformed pipe(Accessory)>

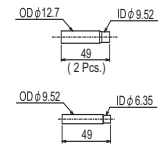

ID: Inner Diameter OD: Outer Diameter

CMY-Y202-G2

Ref.: CMY_Y202_G2_EXD_EUDB_SI mm

For Gas pipe:

For Liquid pipe:

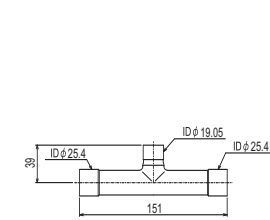

<Deformed pipe(Accessory)>

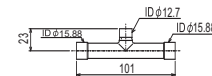
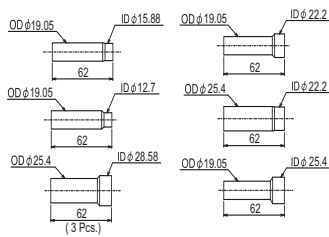

<Deformed pipe(Accessory)>

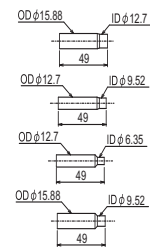

ID: Inner Diameter OD: Outer Diameter

7-2. OUTDOOR TWINNING KIT

For PURY-(E)P-YSHM-A, following optional Outdoor Twinning Kit is needed to use to combine to refrigerant flows of its PURY-(E)P-YHM-A. Details of selecting the proper kit should be referred to the System Design Section.

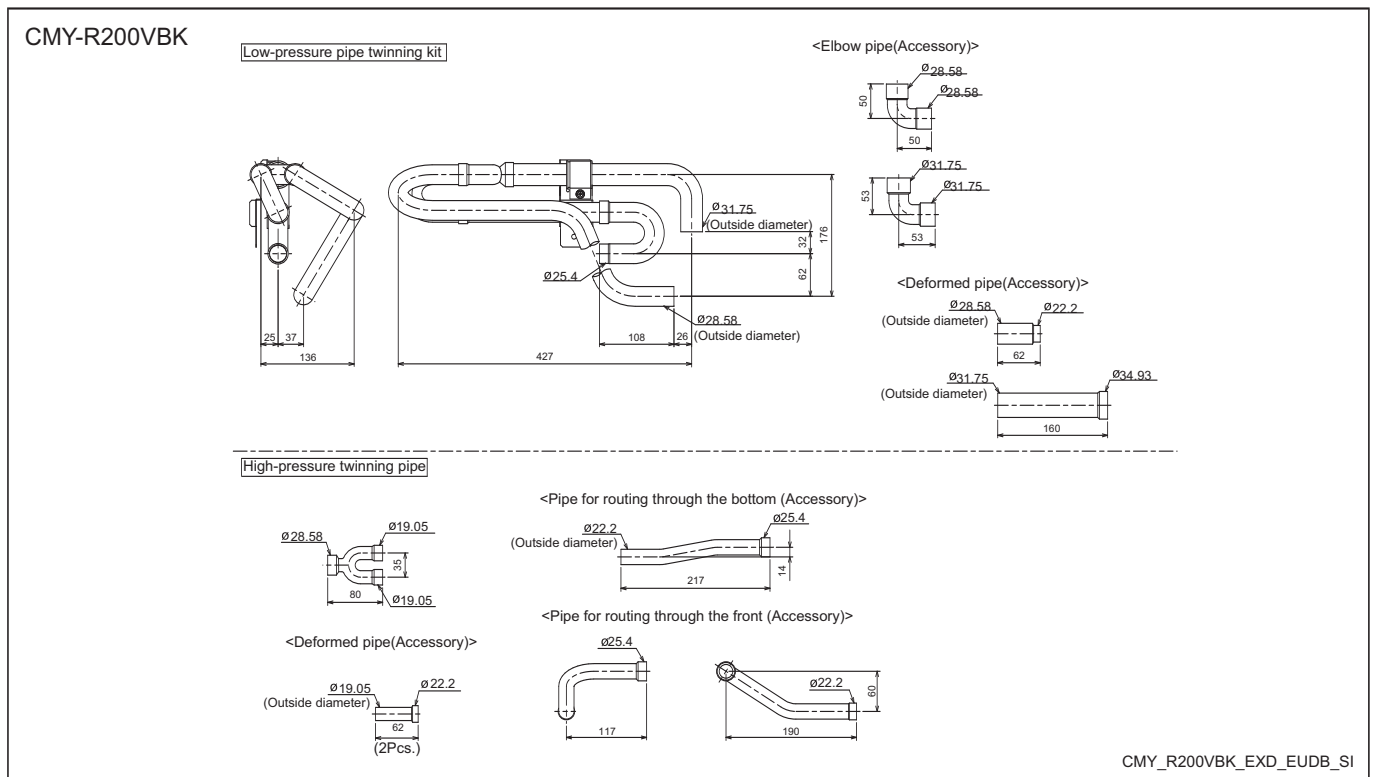
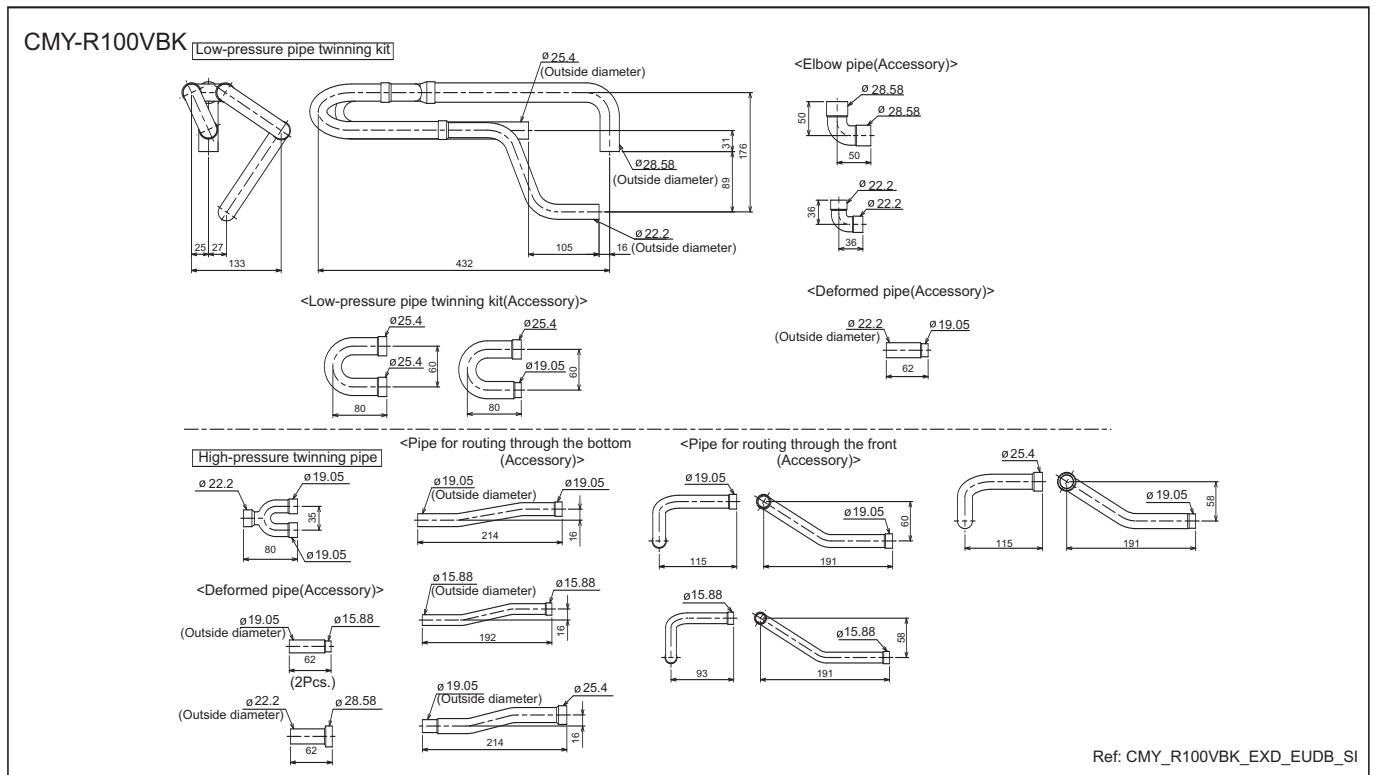

Note 1. Reference the attitude angle of the branch pipe below the fig.

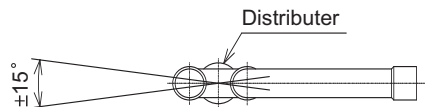

The angle of the branch pipe for high pressure is within $\pm 15^\circ$ against the ground.

2. Use the attached pipe to braze the port-opening of the distributor.
3. Pipe diameter is indicated by inside diameter.

7-3. JOINT KIT CMY-R160-J FOR BC CONTROLLER

Joint kit "CMY-R160-J" for BC controller is used to combine 2 ports of the BC controller at a PURY-(E)P-Y(S)HM-A system so as to enable down-stream Indoor capacity above P140 as shown in Fig. 1.

The Joint kit include following items:

① Instruction	② Joint pipe (for liquid side)	③ Joint pipe (for gas side)	④ Cover 1	⑤ Cover 2 (for gas side)	⑥ Cover 3 (for liquid side)	⑦ Band	⑧ Reducer
This sheet 1pc	1pc	1pc	2pcs	1pc	1pc	8pcs	2pc

Ref.: WT04350X01_01

② Joint pipe (for liquid side)

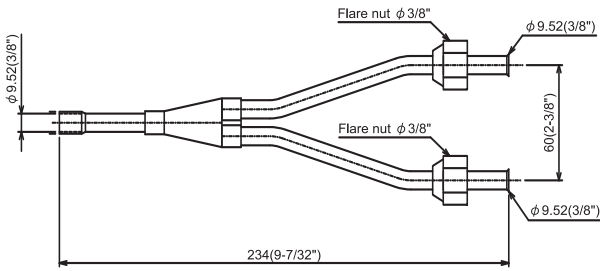

③ Joint pipe (for gas side)

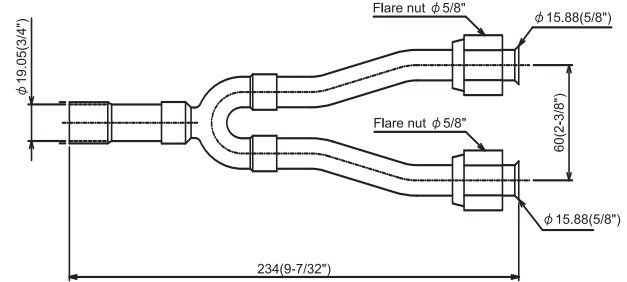

mm(in.)

Ref.: W901616

1. Designing CMY-R160-J to a PURY-(E)P-Y(S)HM-A system

The maximum down-stream Indoor capacity for 1 port of BC controller is P140. When the down-stream Indoor capacity is above P140, Joint kit CMY-R160-J is needed to combined 2 ports of BC controller to enlarge the capacity, like Group 2 and 3 in Fig. 1.

Maximum 3 Indoor units are allowed to connect to 1 port of BC controller or 2 combined ports of BC controller using CMY-R160-J.

When connecting Indoor units to 1 port of BC controller or 2 combined ports of BC controller using CMY-R160-J or CMY-Y102S-G2 is applicable, like Group 1 and 2 in Fig. 1

Caution: Mixed cooling and heating mode at the same time for Indoor units connecting to 1 port or 2 combined ports is not available.

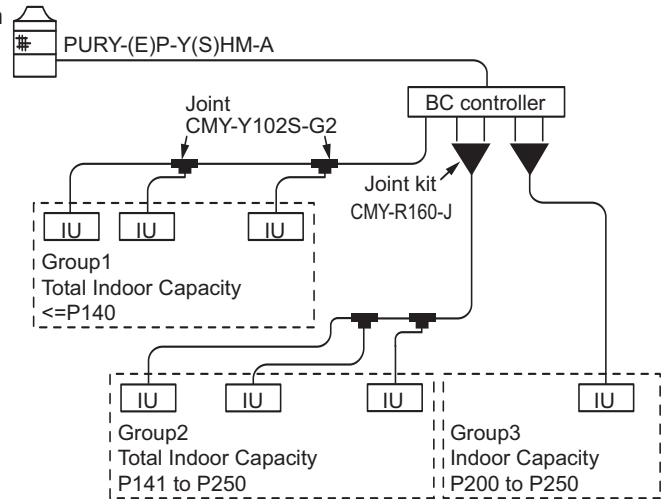

Fig.1. CMY-R160-J applying scheme

Ref.: WT04350X01_02

2. Piping at the installation site

The connection of CMY-R160-J to BC controller and pipe leading to Indoor units is referable to Fig. 2. Non-oxidized brazing is necessary. All piping must be careful to avoid foreign material getting inside.

After piping and air-tight testing, insulation work to the Joint and pipe should be done. Details is available at the Installation Manual.

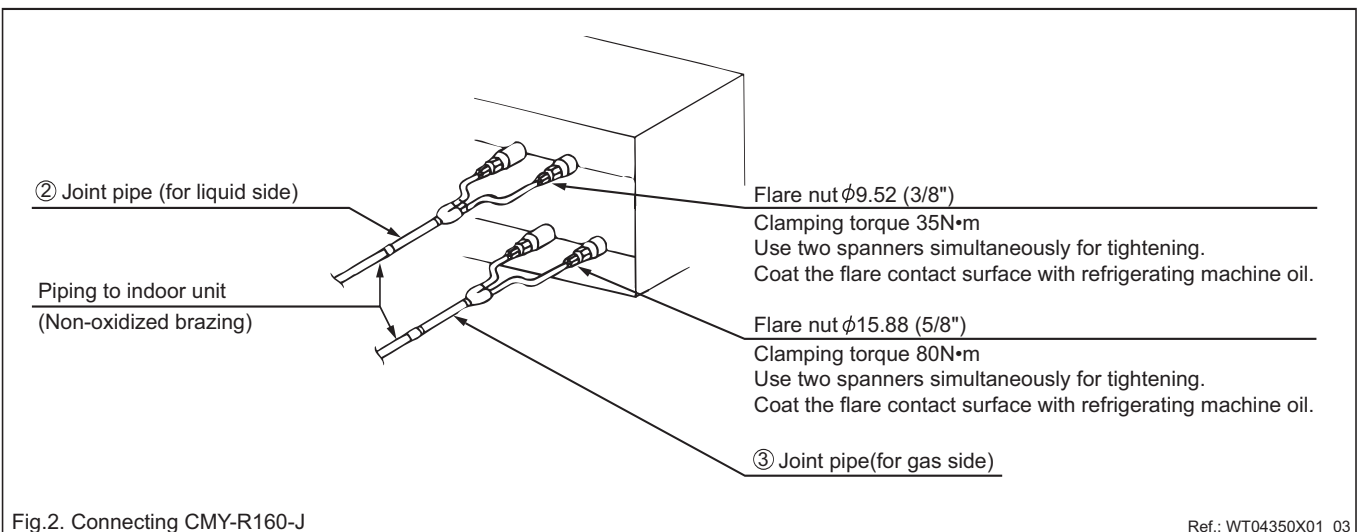

Fig.2. Connecting CMY-R160-J

Ref.: WT04350X01_03

Ref: CMY_R160_J_DOC_EUDB